

SHEATHING, TAPE AND CLADDINGS

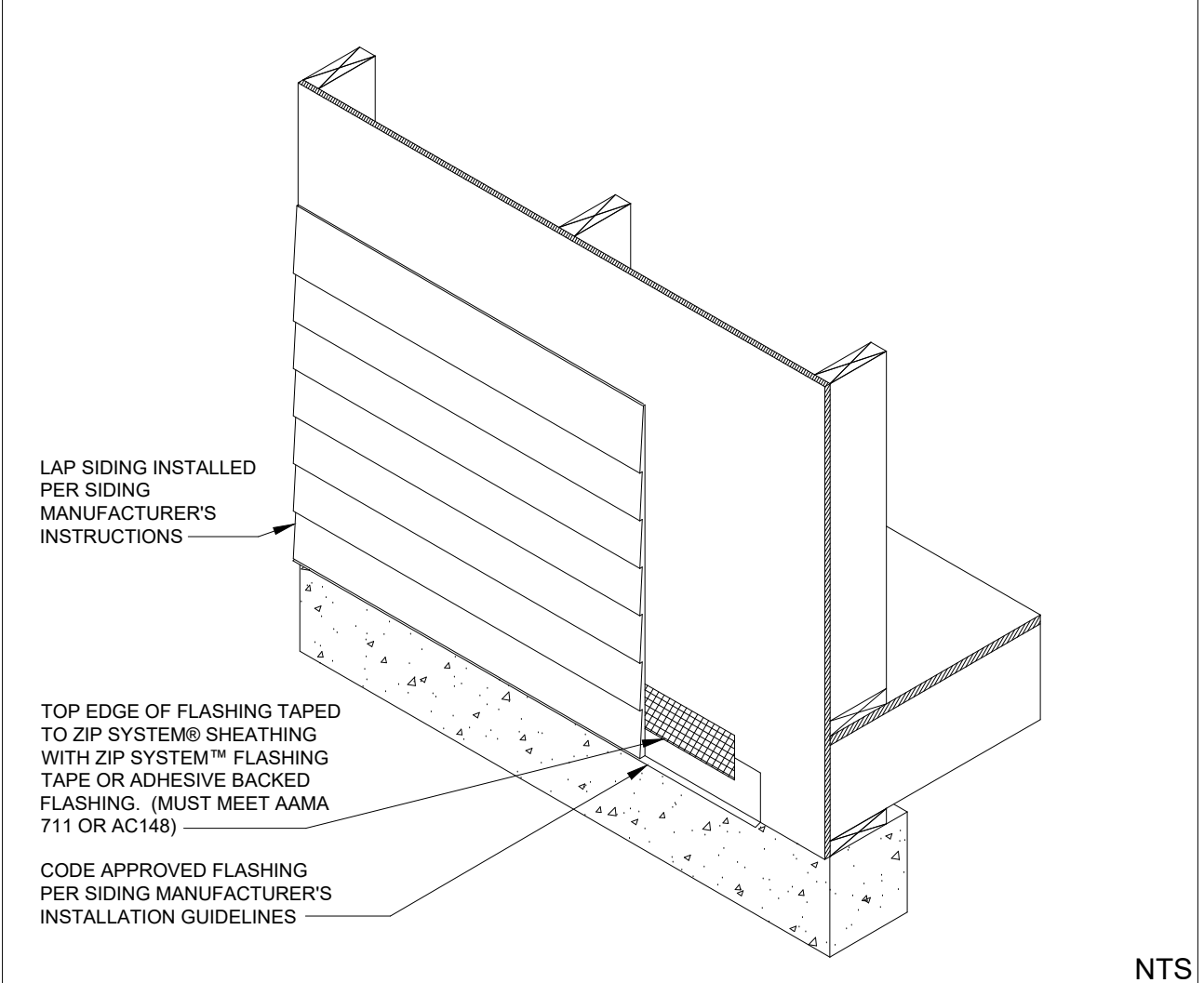
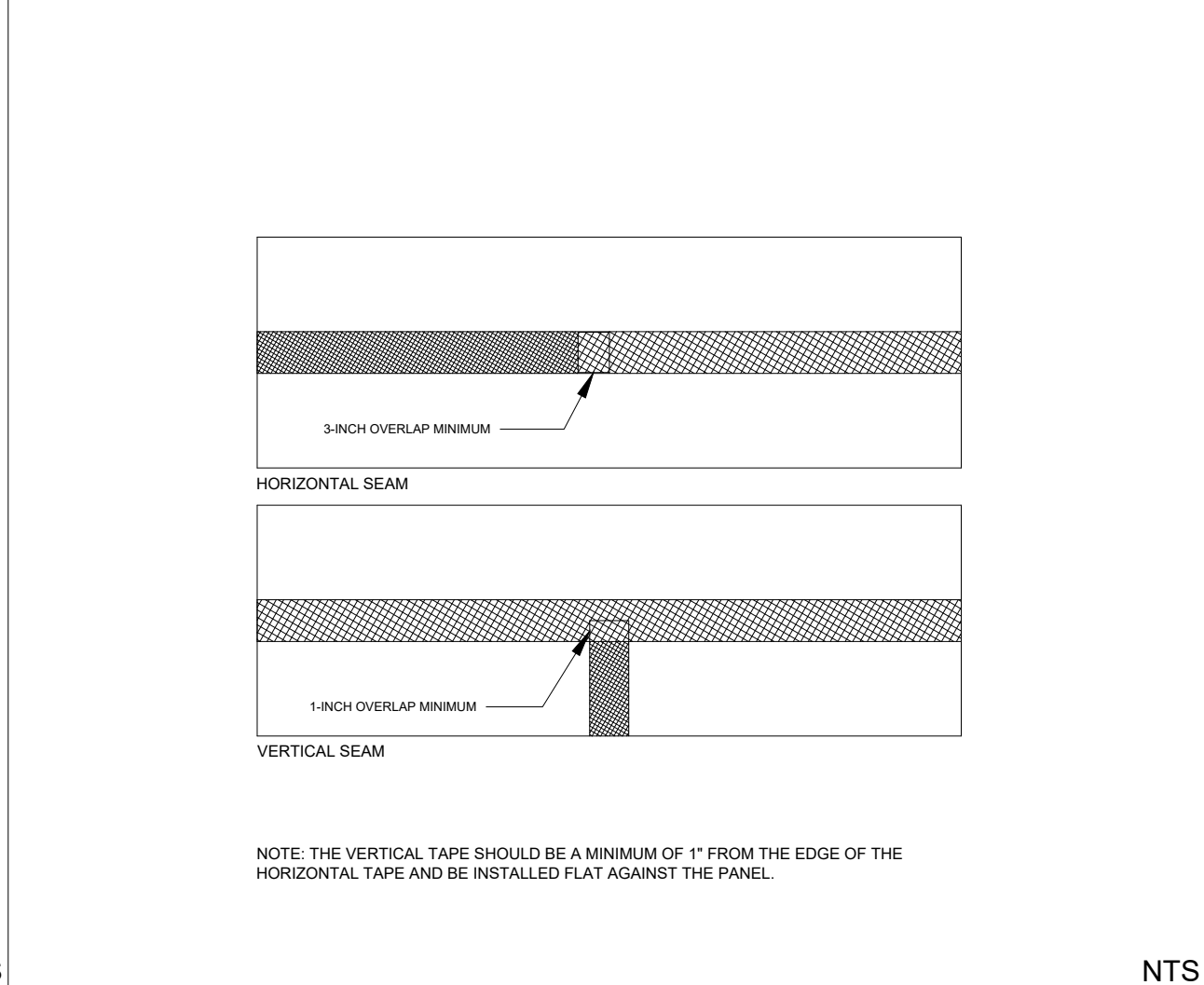
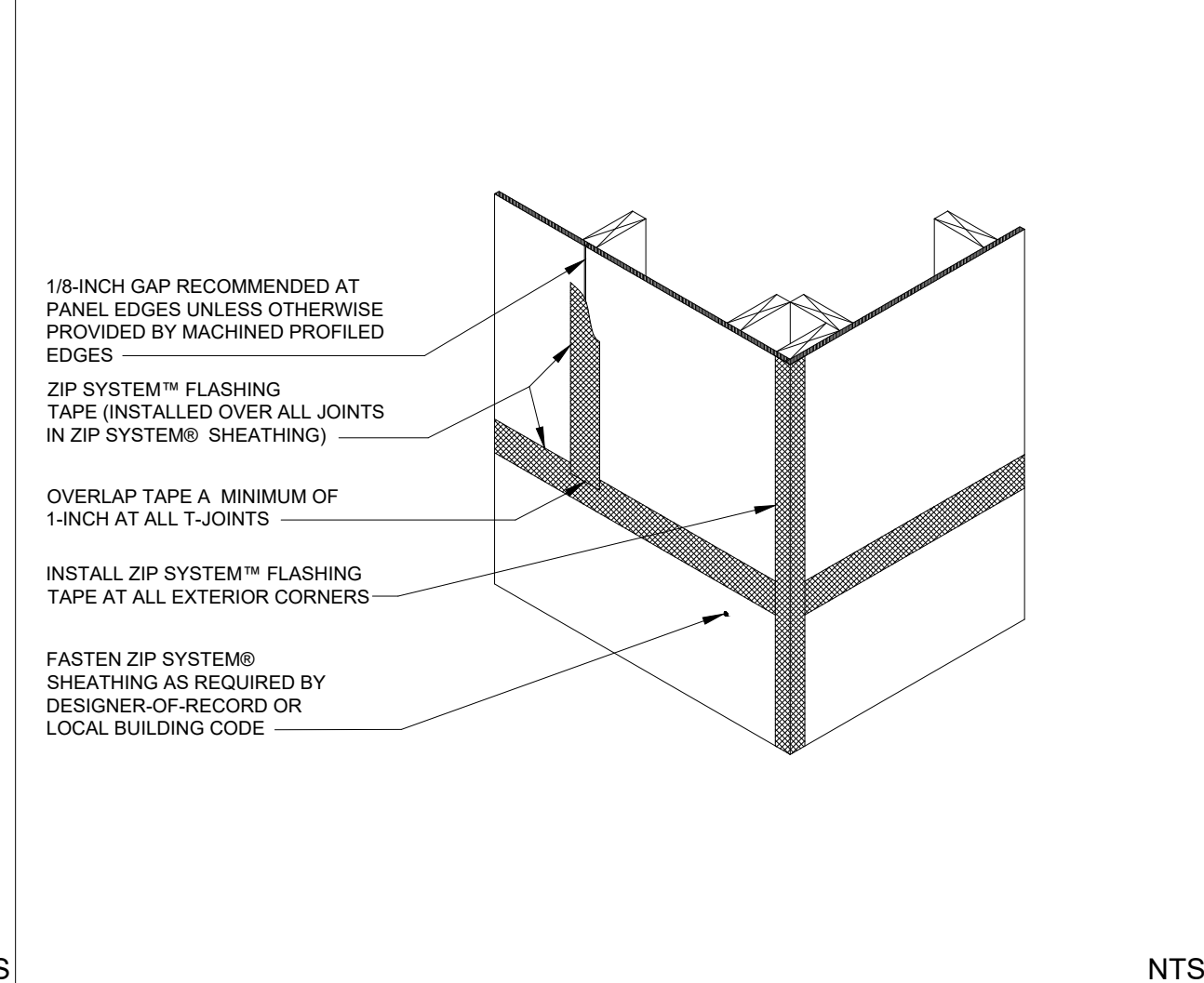
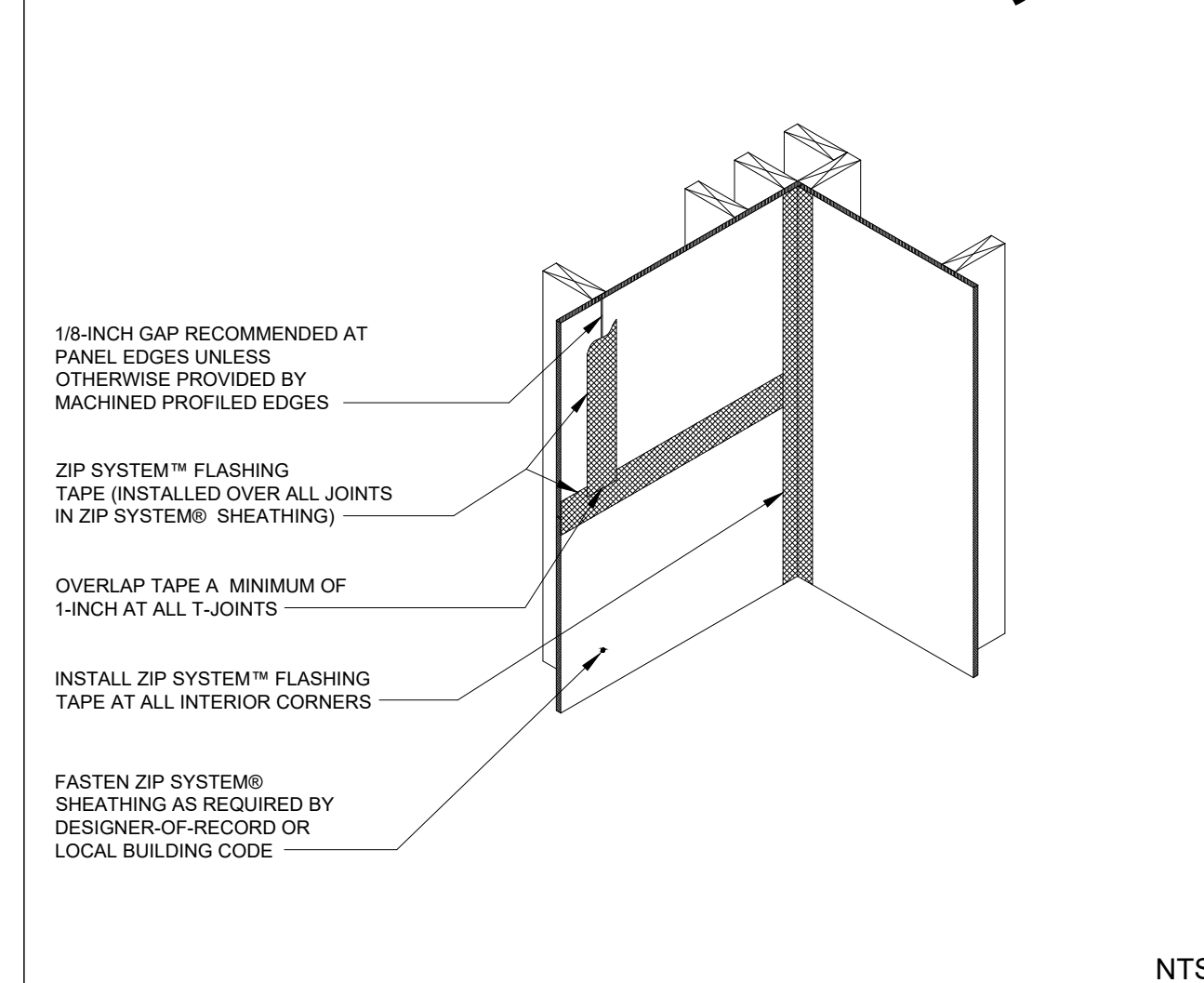

ZIP SYSTEM® SHEATHING GENERAL NOTES

ZIP SYSTEM® SHEATHING IS A STRUCTURAL PANEL DESIGNED TO FUNCTION AS BOTH A STRUCTURAL SHEATHING PANEL AND A WATER-RESISTIVE BARRIER (WRB) TO STREAMLINE THE INSTALLATION PROCESS IN TYPE V CONSTRUCTION FOR WALL/ROOF APPLICATIONS AND IN TYPE III FOR ROOF APPLICATIONS. ZIP SYSTEM IS CODE-RECOGNIZED AS A WRB FOR A WALL APPLICATION PER ESR-1474 AND AS A ROOF UNDERLAYMENT PER ESR-1473. ALL ZIP SYSTEM PANEL SEAMS MUST BE TAPED USING THE ZIP SYSTEM™ FLASHING TAPE OR ZIP SYSTEM™ LIQUID FLASH. WHEN INSTALLING THE FLASHING TAPE, A RUBBER-HEADED ROLLER MUST BE USED. ZIP SYSTEM SHEATHING PANELS ARE DOC PS 2 STRUCTURAL 1 RATED COMPLIANT WOOD STRUCTURAL PANELS (WSP) HAVING AT LEAST THE SAME STRUCTURAL PERFORMANCE AS A WSP OF EQUIVALENT THICKNESS. FOR SHEAR WALL INFORMATION, SEE THE TECHNICAL TIP "SHEAR CAPACITY OF WOOD STRUCTURAL PANEL" AT HUBERWOOD.COM. ZIP SYSTEM PANELS ARE AVAILABLE IN THE FOLLOWING THICKNESSES.

24/16, STRUCTURAL 1, 7/16" PERF CATEGORY
 4'x8' | 4'x9' | 4'x10' | 4'x12'
 | 4'x8' 1-1/8" | 4'x9' 1-1/8" | 4'x10' 1-1/8" | 4'x12' 1-1/8"

32/16, STRUCTURAL 1, 1/2" PERF CATEGORY
 4'x8' | 4'x9' | 4'x10'

40/20, STRUCTURAL 1, 5/8" PERF CATEGORY
 4'x8' | 4'x9' | 4'x10'

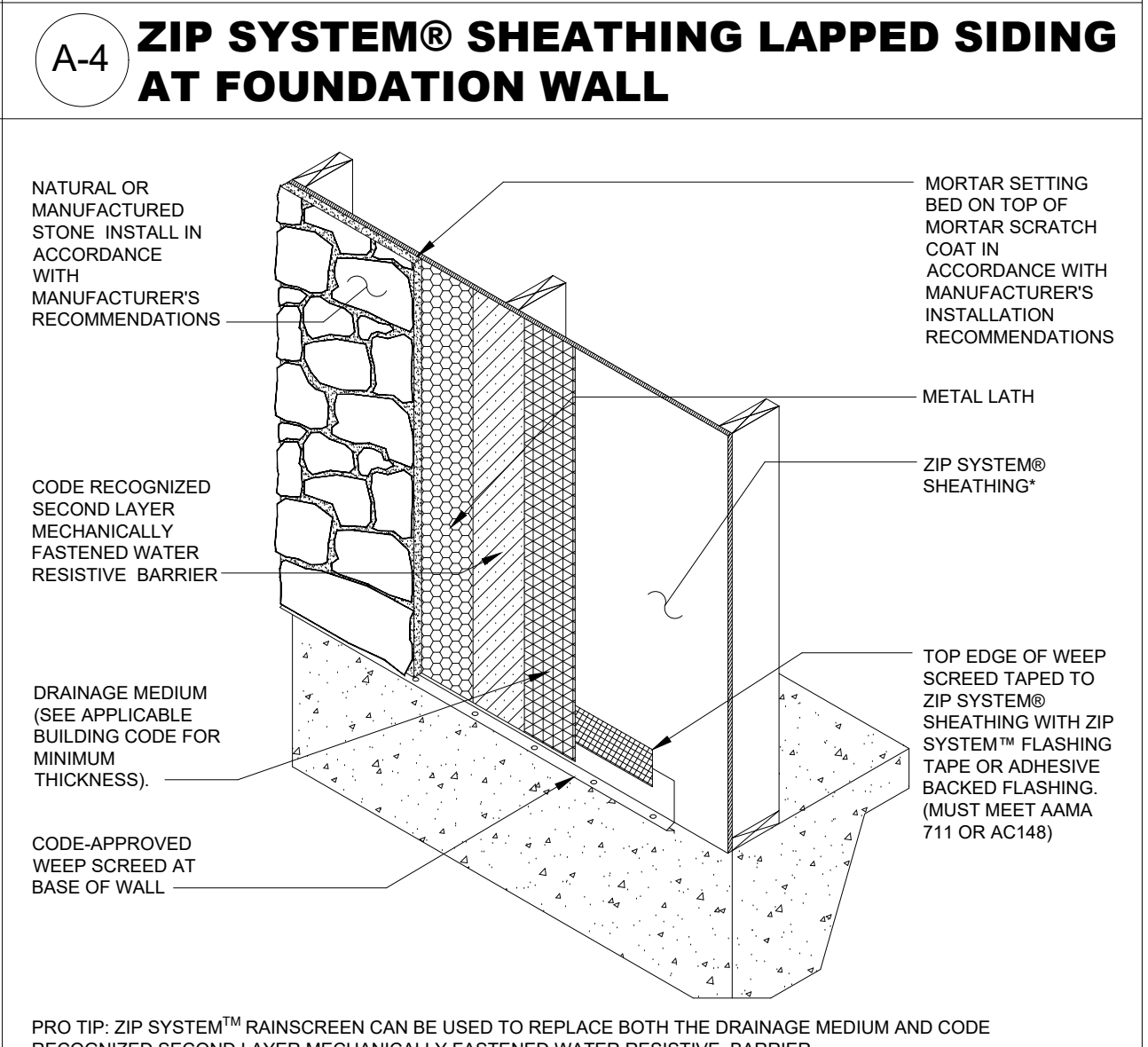
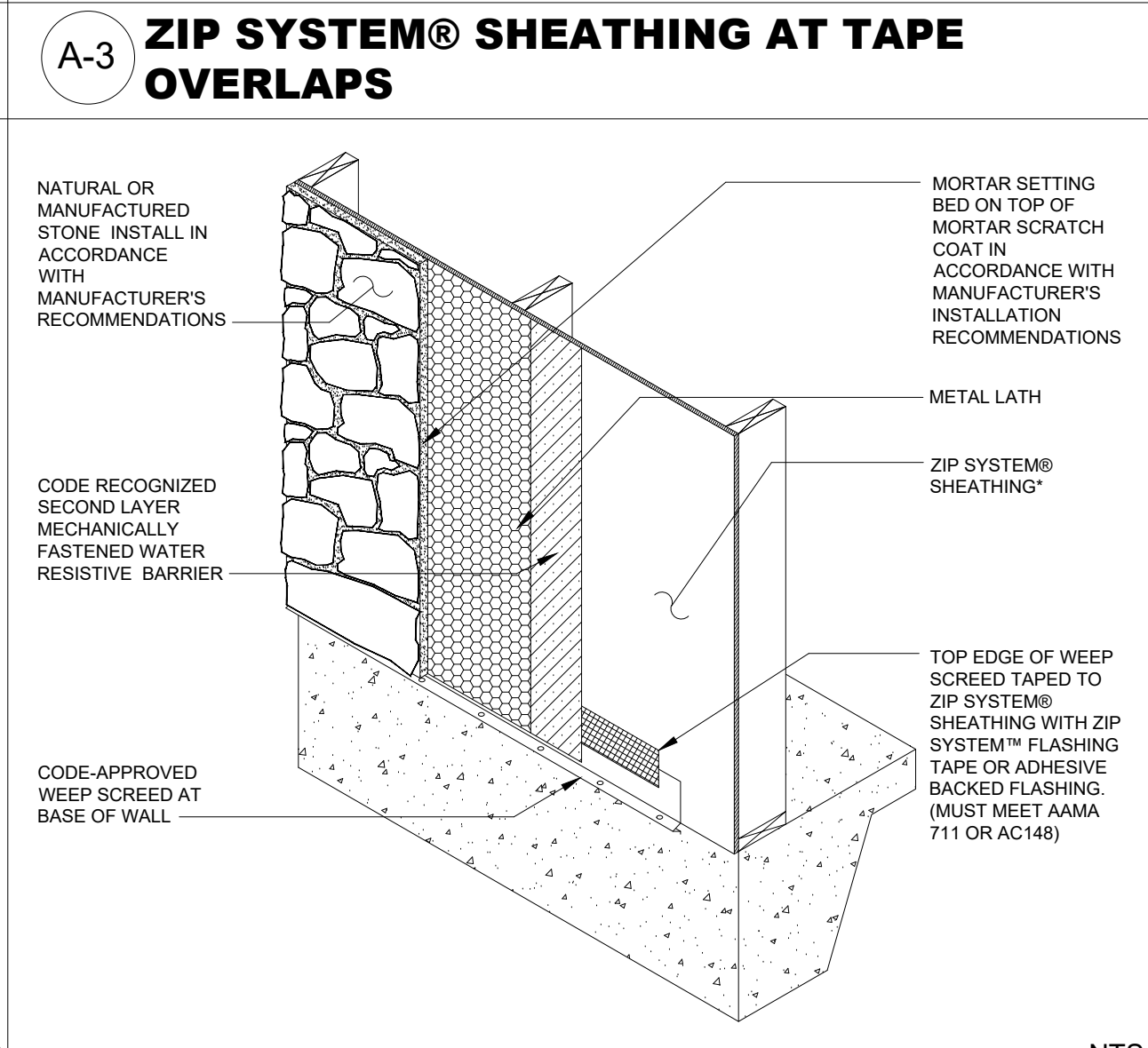
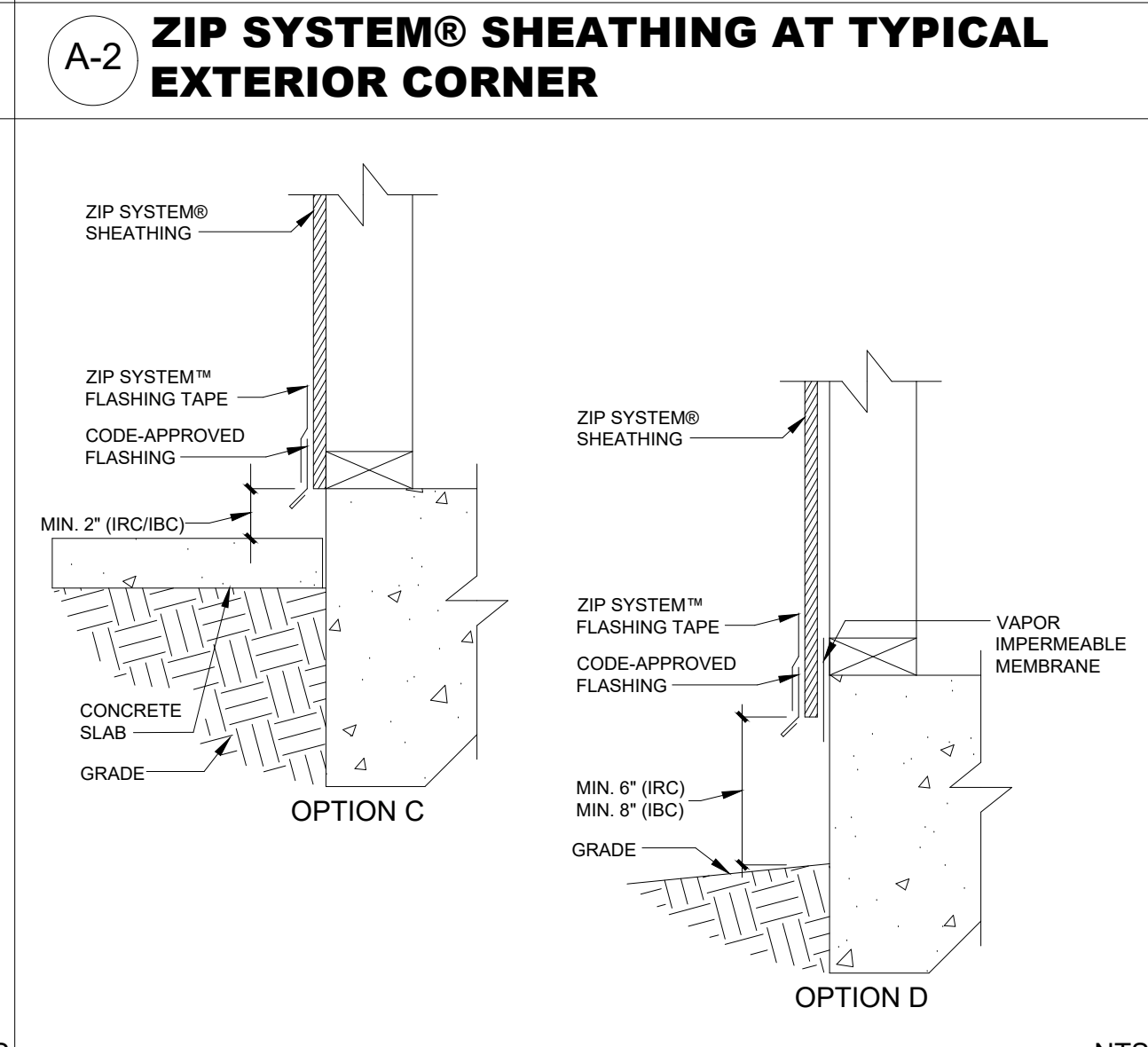
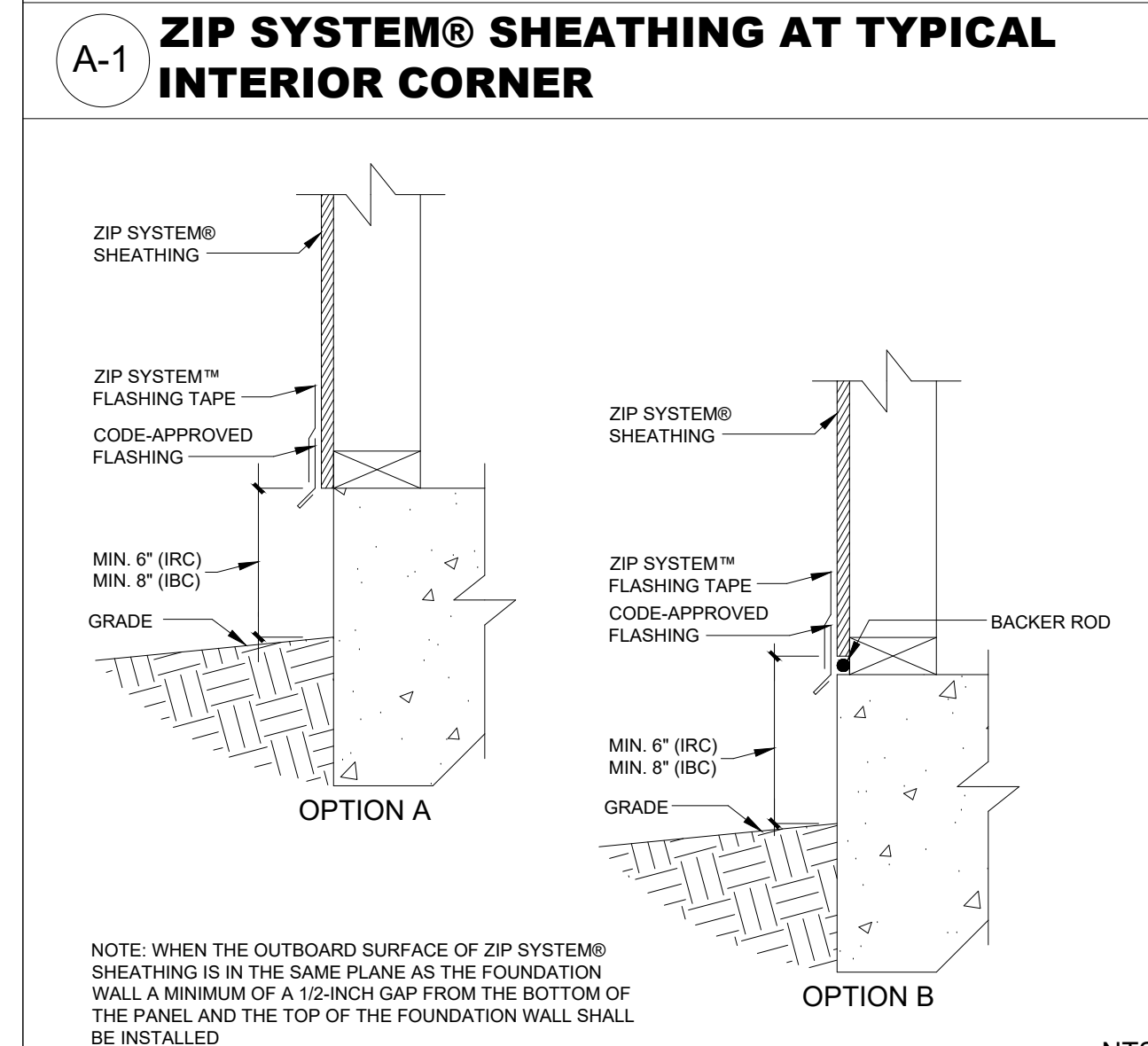

ZIP SYSTEM SHEATHING - WALL INSTALLATION INSTRUCTIONS

1. INSTALL ZIP SYSTEM PANELS WITH THE WATER-RESISTIVE BARRIER FACING OUT. PANELS CAN BE ORIENTED VERTICALLY OR HORIZONTALLY. INSTALL BLOCKING WHEN USED AS A SHEAR WALL, PER THE STRUCTURAL PANELS, OR PER LOCAL CODE REQUIREMENTS. SPACE PANELS A MIN. 1/8".
2. FASTEN THE PANELS TO THE FRAMING USING CODE-RECOGNIZED FASTENERS WITH MAXIMUM SPACING OF 6" O.C. ALONG SUPPORTED EDGES AND 12" O.C. AT INTERMEDIATE SUPPORTS. IT IS THE RESPONSIBILITY OF THE GENERAL CONTRACTOR TO VERIFY PROPER TYPE AND SPACING OF FASTENERS. A TIGHTER FASTENING MAY BE REQUIRED DEPENDING ON STRUCTURAL REQUIREMENTS. THE GC IS RESPONSIBLE FOR ENSURING OVER-DRIVEN FASTENERS AND SHINERS ARE ADDRESSED.
3. TAPE ALL SEAMS USING ZIP SYSTEM FLASHING TAPE ENSURING THE TAPE IS CENTERED OVER THE SEAM WITHIN ± 1/2". USE A RUBBER-HEADED ROLLER TO APPLY ADEQUATE PRESSURE AND SMOOTH OUT ANY WRINKLES.
4. VERTICAL OR HORIZONTAL TAPE SPLICES SHOULD OVERLAP A MIN. 3". AT T-JOINTS, THE TAPE PIECES SHOULD OVERLAP A MIN. 1".

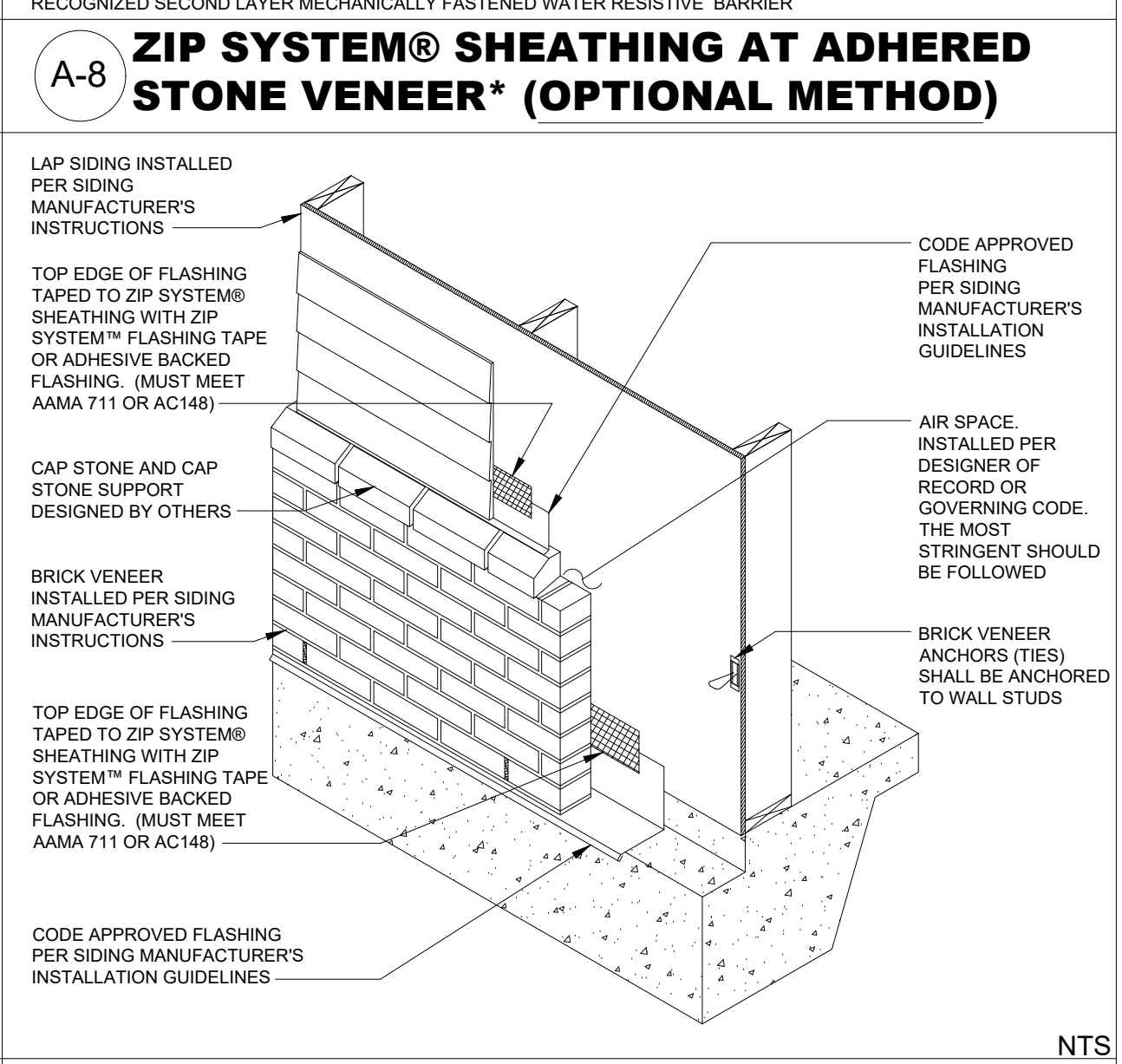
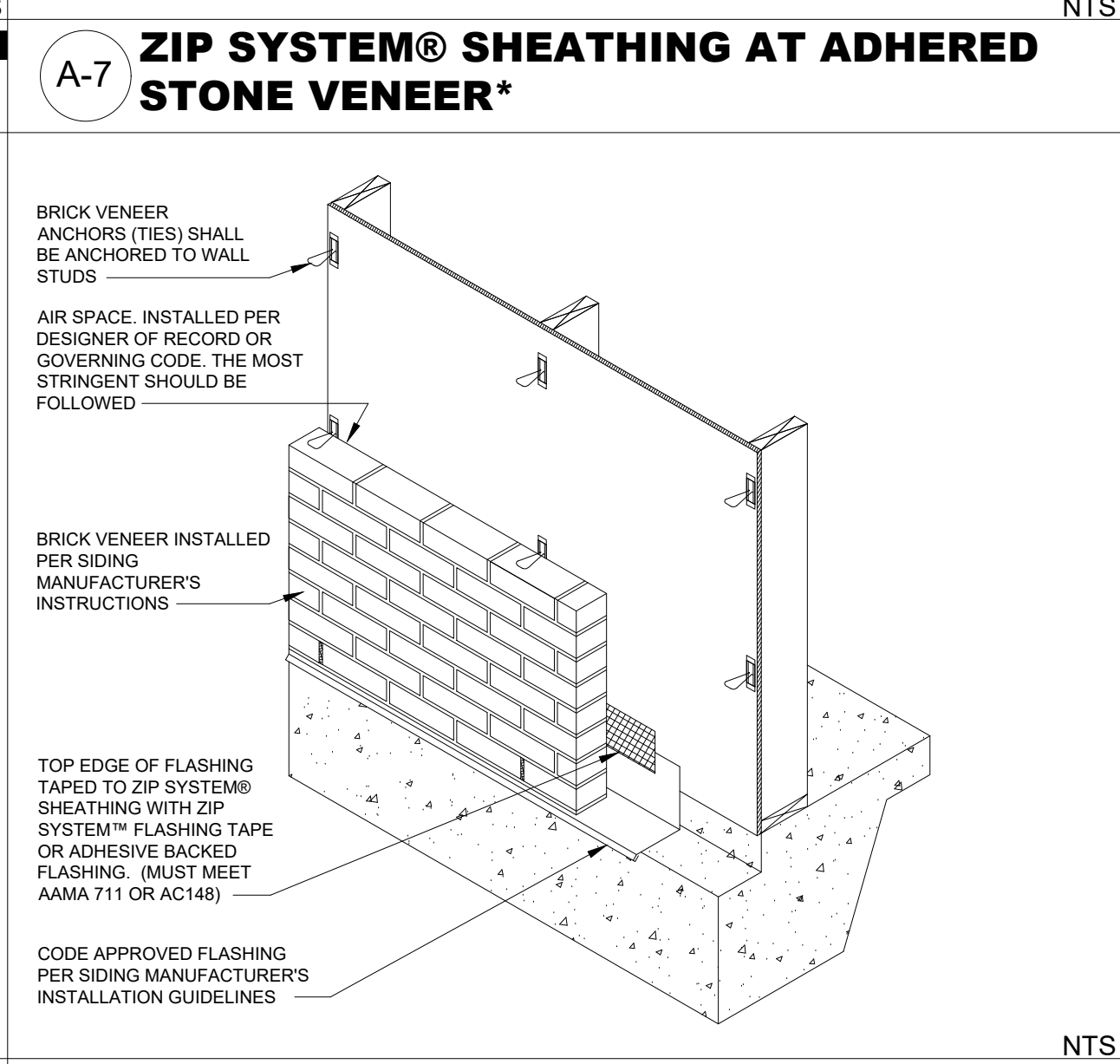
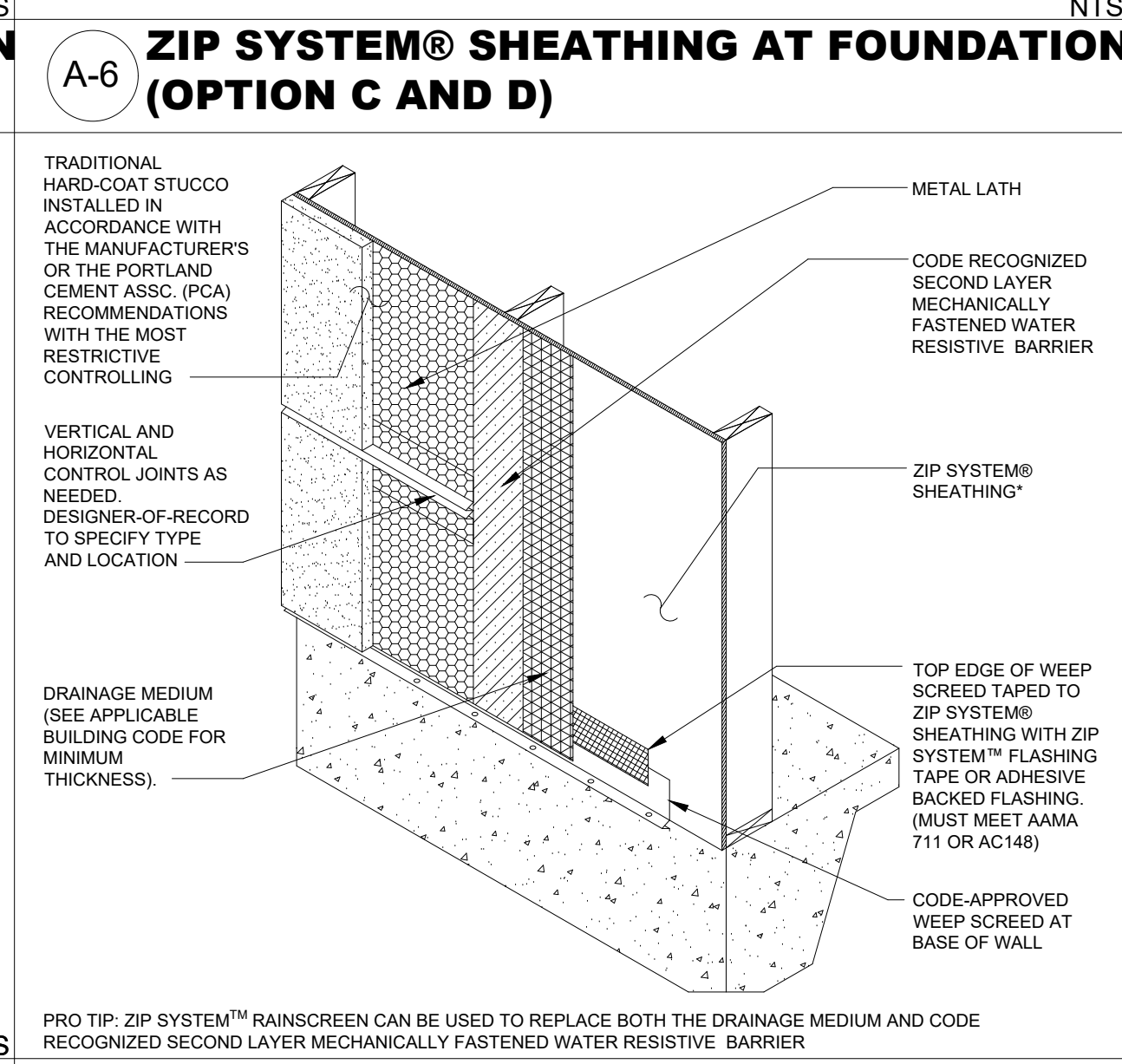
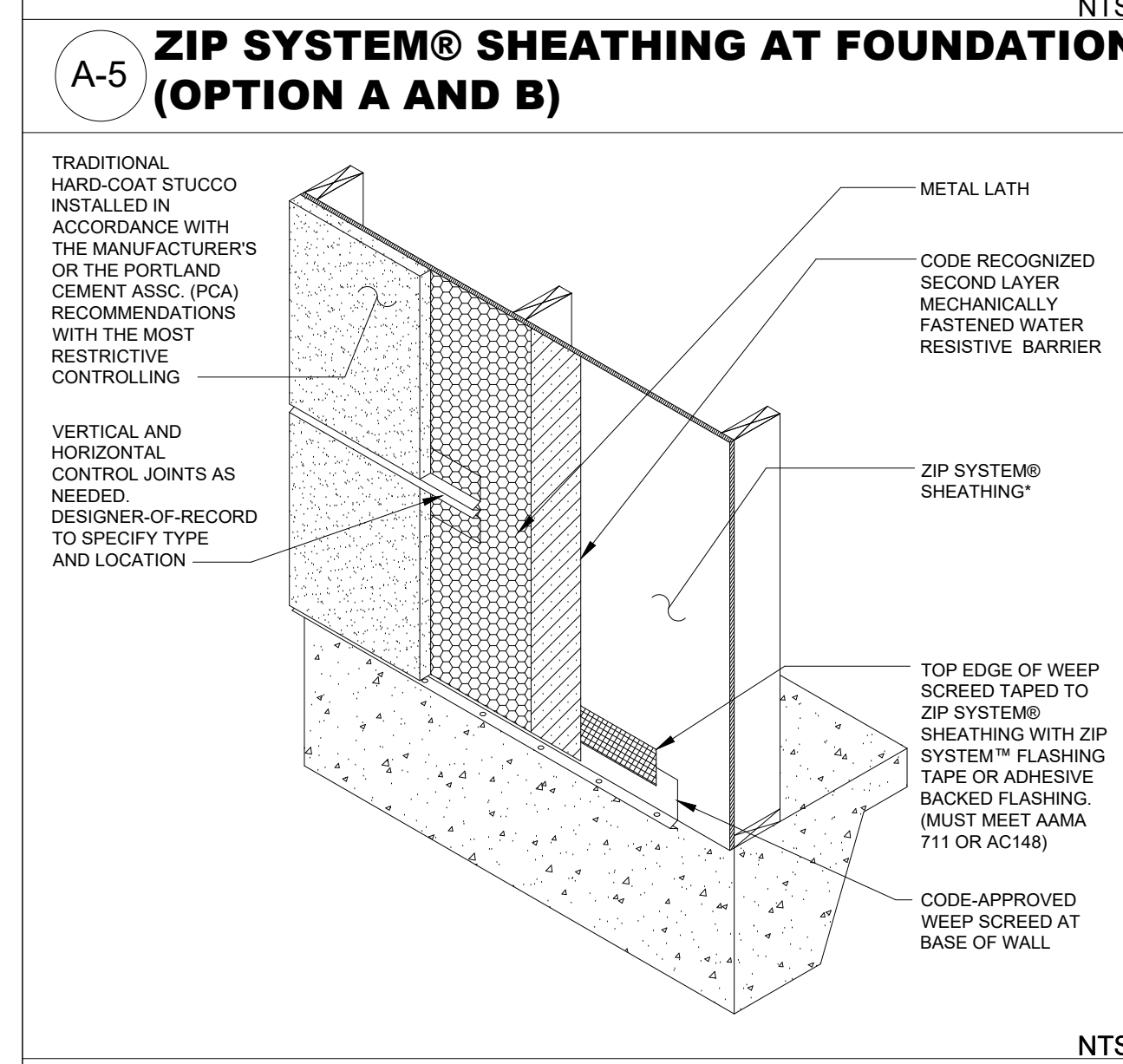

DISCLAIMER

THE DETAILS SHOWN ON THIS PAGE ARE TYPICAL AND FOR GENERAL PURPOSE. VISIT HUBERWOOD.COM FOR MORE INFORMATION ON FINISHED WALL COVERINGS, DETAILS, AND APPLICATIONS. SOME DETAILS ARE RECOMMENDATIONS BY HEW AND NOT REQUIREMENTS; SEE THE ZIP SYSTEM INSTALLATION MANUAL FOR MORE INFORMATION. A LIBRARY OF DETAILS AND TECHNICAL TIPS ARE AVAILABLE AT HUBERWOOD.COM.

FOR ADDITIONAL QUESTIONS CONTACT US BY EMAIL AT TECHQUESTIONS@HUBER.COM OR BY PHONE AT 1-800-933-9220 EXT. 2716

HUBER ENGINEERED WOODS, LLC
 10925 DAVID TAYLOR DRIVE
 SUITE 300
 CHARLOTTE, NC 28262

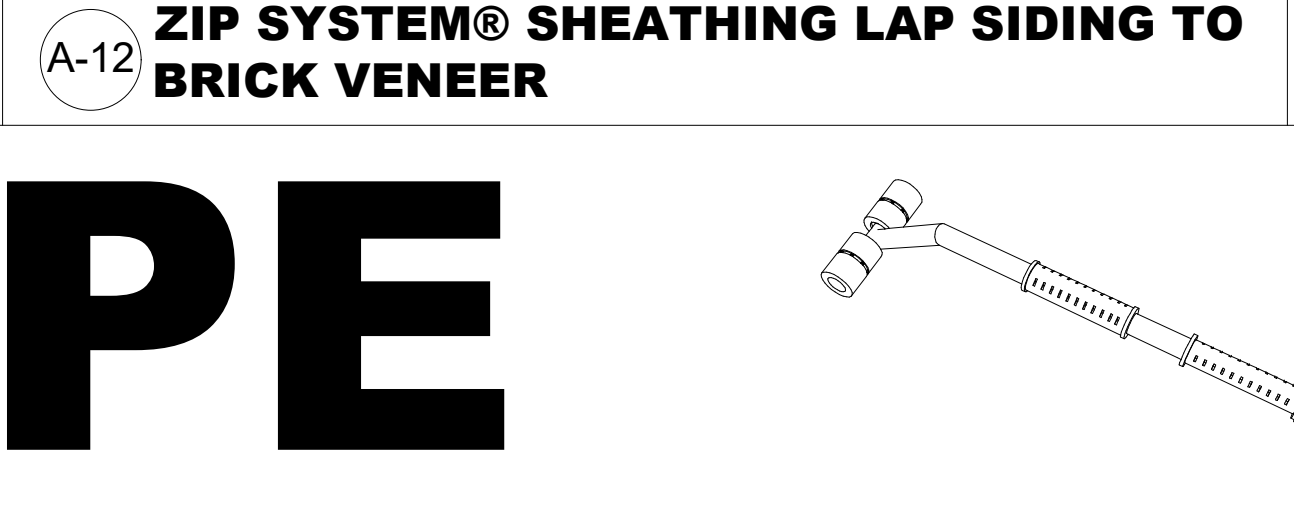
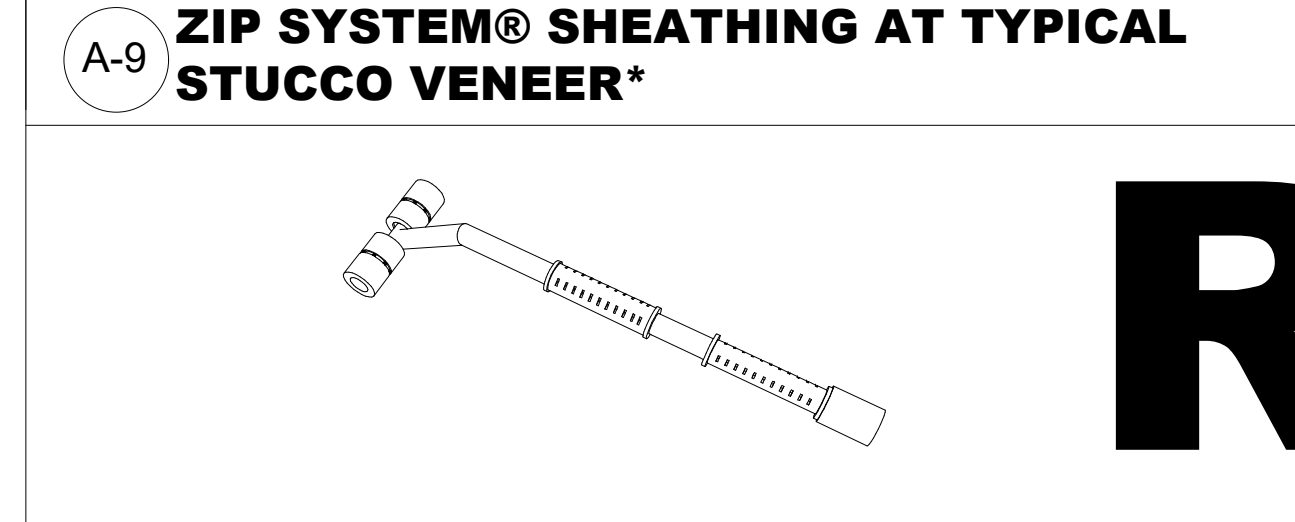

ROLL THE TAPE

TRANSITIONS AND MEP'S

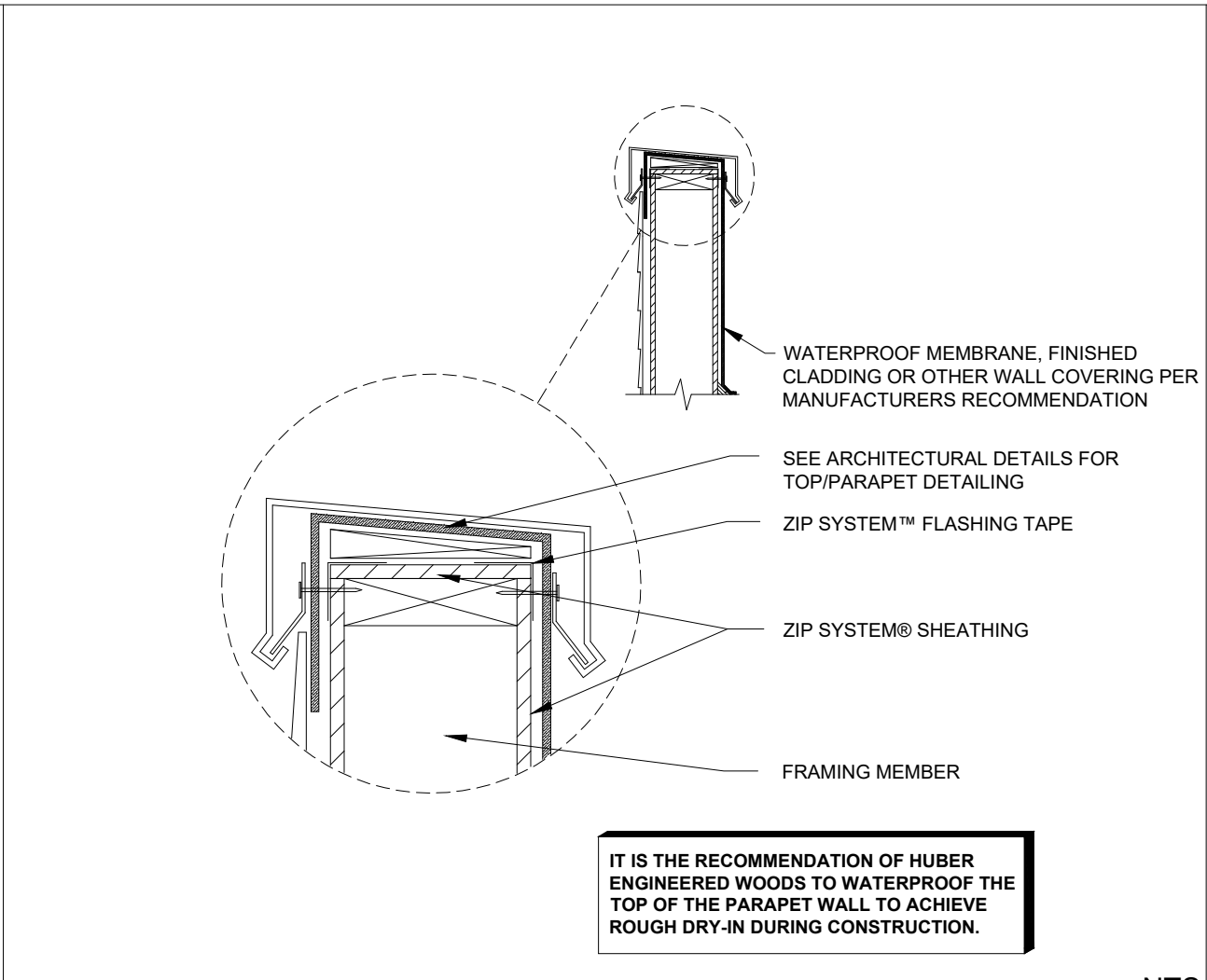
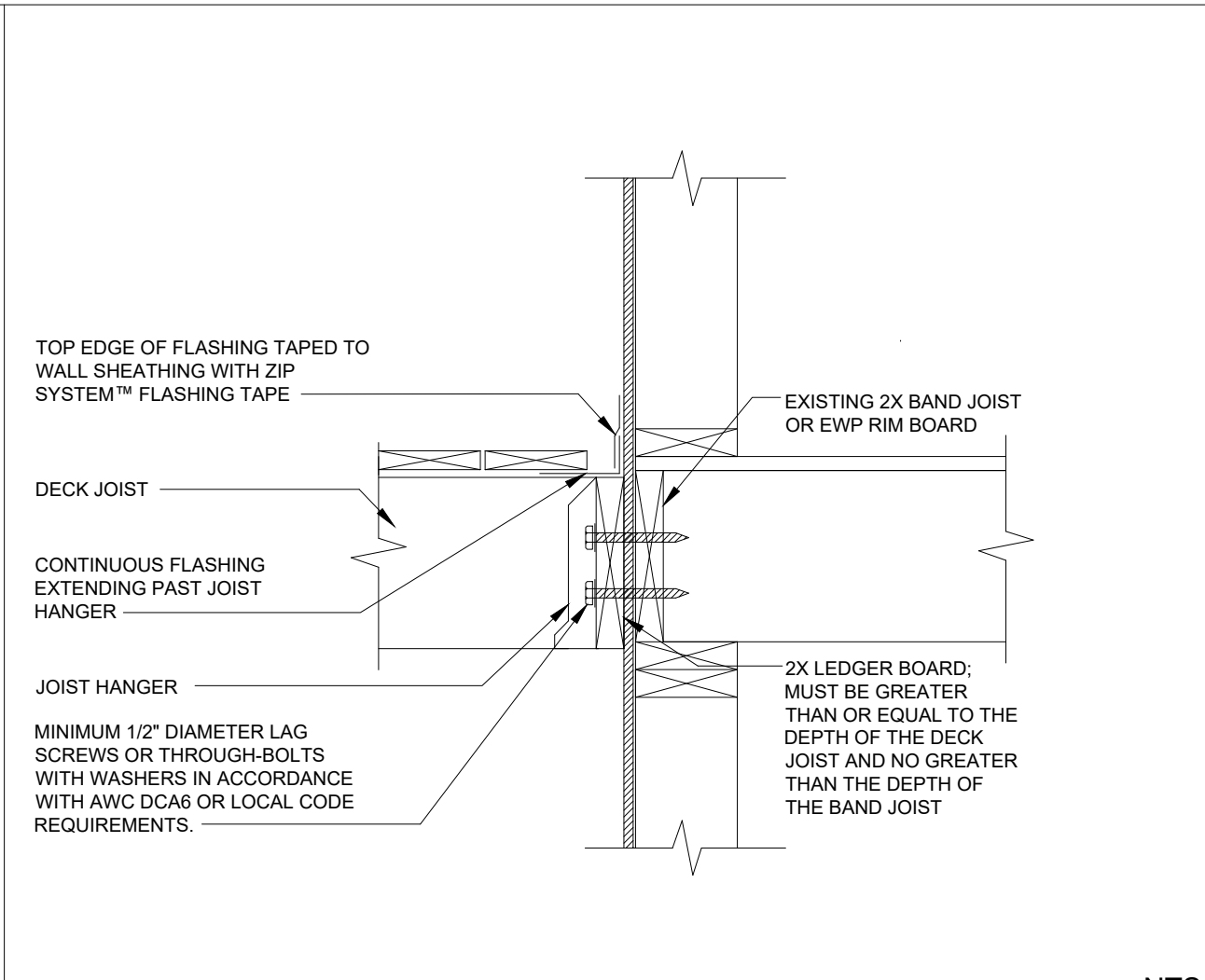
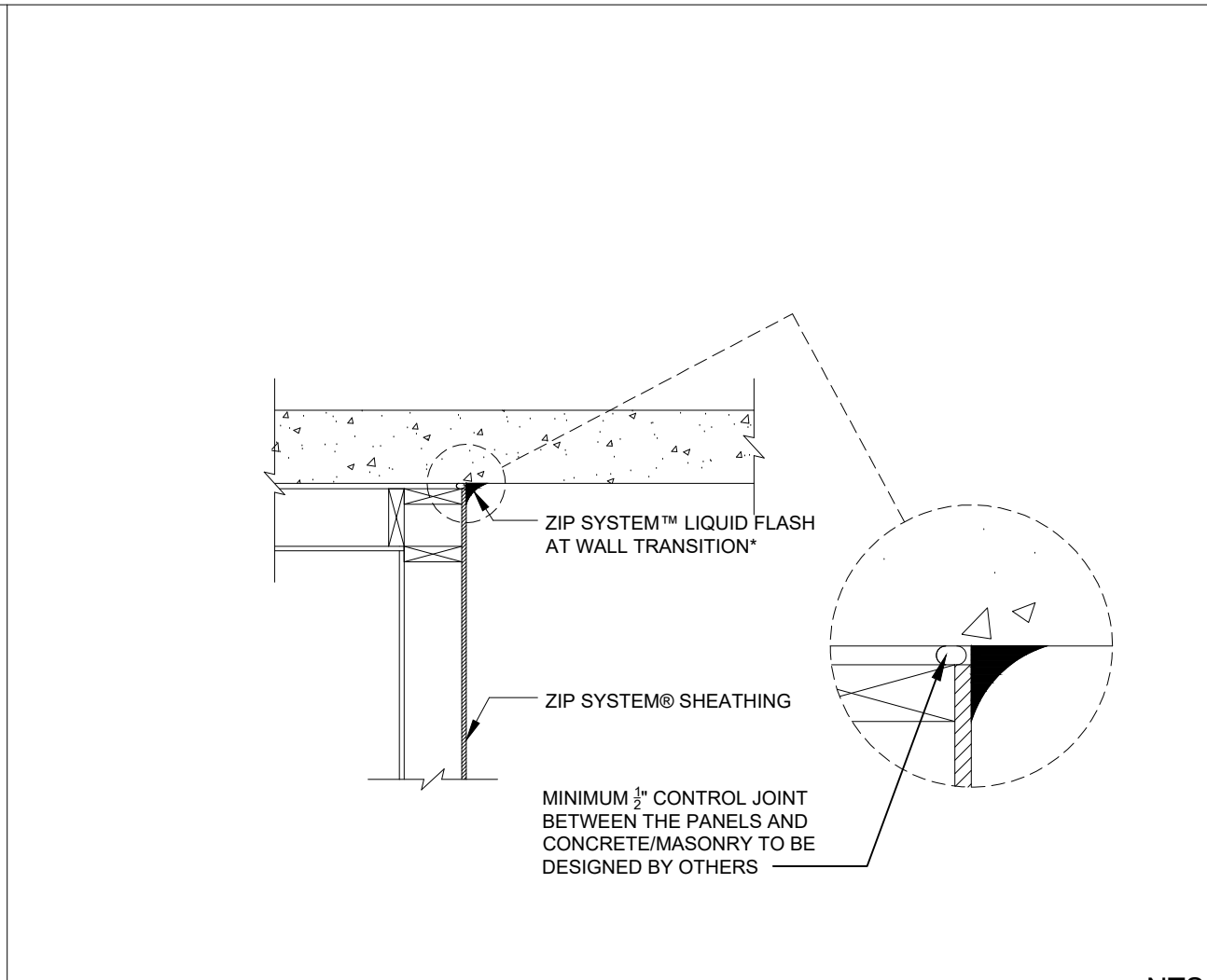
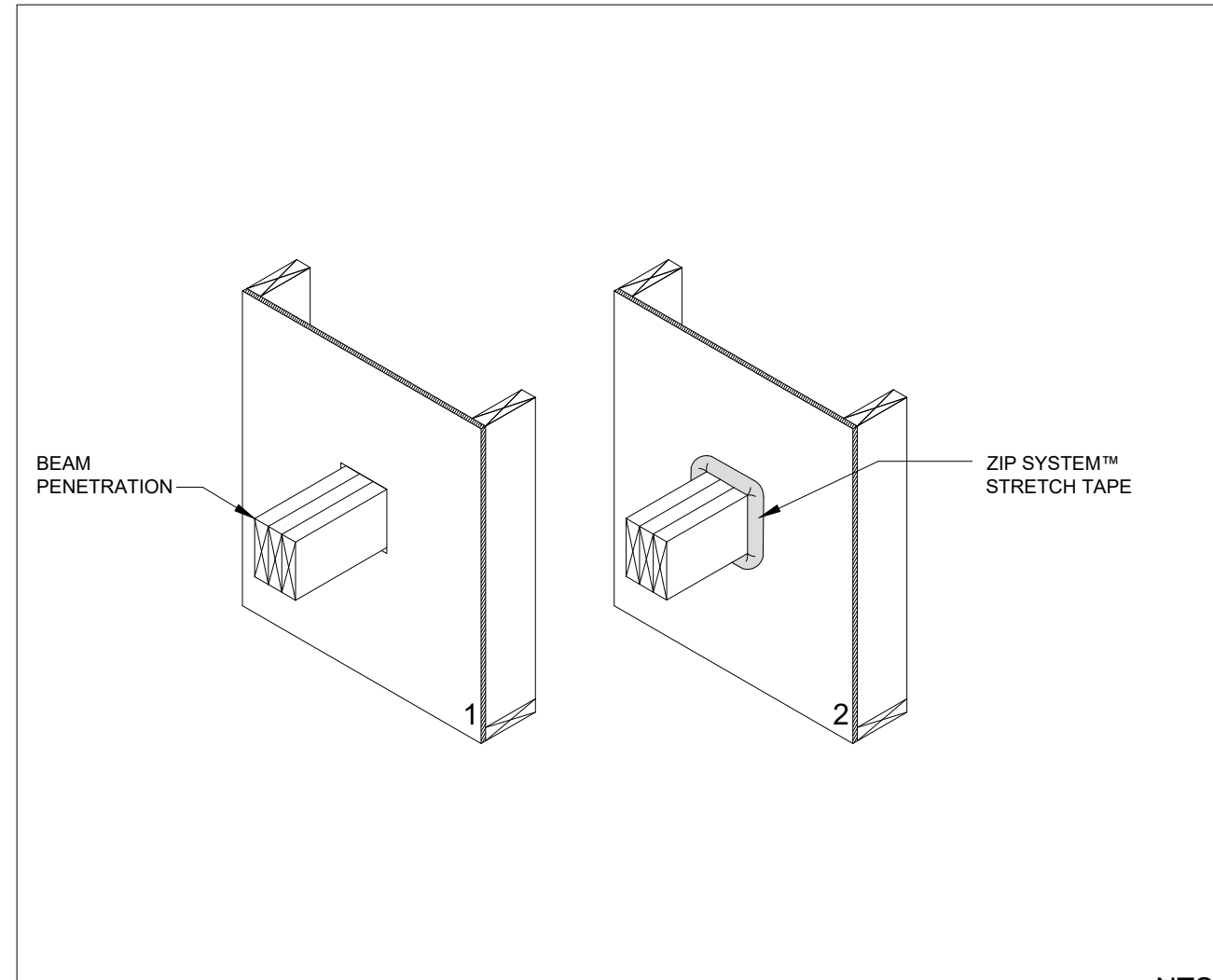

ZIP SYSTEM® SHEATHING GENERAL NOTES

ZIP SYSTEM® SHEATHING IS A STRUCTURAL PANEL DESIGNED TO FUNCTION AS BOTH A STRUCTURAL SHEATHING PANEL AND A WATER-RESISTIVE BARRIER (WRB) TO STREAMLINE THE INSTALLATION PROCESS IN TYPE V CONSTRUCTION FOR WALL/ROOF APPLICATIONS AND IN TYPE III FOR ROOF APPLICATIONS. ZIP SYSTEM IS CODE-RECOGNIZED AS A WRB FOR A WALL APPLICATION PER ESR-1474 AND AS A ROOF UNDERLAYMENT PER ESR-1473. ALL ZIP SYSTEM PANEL SEAMS MUST BE TAPED USING THE ZIP SYSTEM™ FLASHING TAPE OR ZIP SYSTEM™ LIQUID FLASH. WHEN INSTALLING THE FLASHING TAPE, A RUBBER-HEADED ROLLER MUST BE USED. ZIP SYSTEM SHEATHING PANELS ARE DOC PS 2 STRUCTURAL 1 RATED COMPLIANT WOOD STRUCTURAL PANELS (WSP) HAVING AT LEAST THE SAME STRUCTURAL PERFORMANCE AS A WSP OF EQUIVALENT THICKNESS. FOR SHEAR WALL INFORMATION, SEE THE TECHNICAL TIP "SHEAR CAPACITY OF WOOD STRUCTURAL PANEL" AT HUBERWOOD.COM. ZIP SYSTEM PANELS ARE AVAILABLE IN THE FOLLOWING THICKNESSES.

24/16, STRUCTURAL 1, 7/16" PERF CATEGORY
 4x8' | 4x9' | 4x10' | 4x12'
 | 4x8' 1-1/8" | 4x9' 1-1/8" | 4x10' 1-1/8" | 4x12' 1-1/8"
 32/16, STRUCTURAL 1, 1/2" PERF CATEGORY
 4x8' | 4x9' | 4x10'
 40/20, STRUCTURAL 1, 5/8" PERF CATEGORY
 4x8' | 4x9' | 4x10'

BELOW IS A SUMMARY OF THE ZIP SYSTEM SHEATHING INSTALLATION PROCESS. PLEASE VISIT HUBERWOOD.COM TO ACCESS THE COMPLETE ZIP SYSTEM INSTALLATION MANUAL

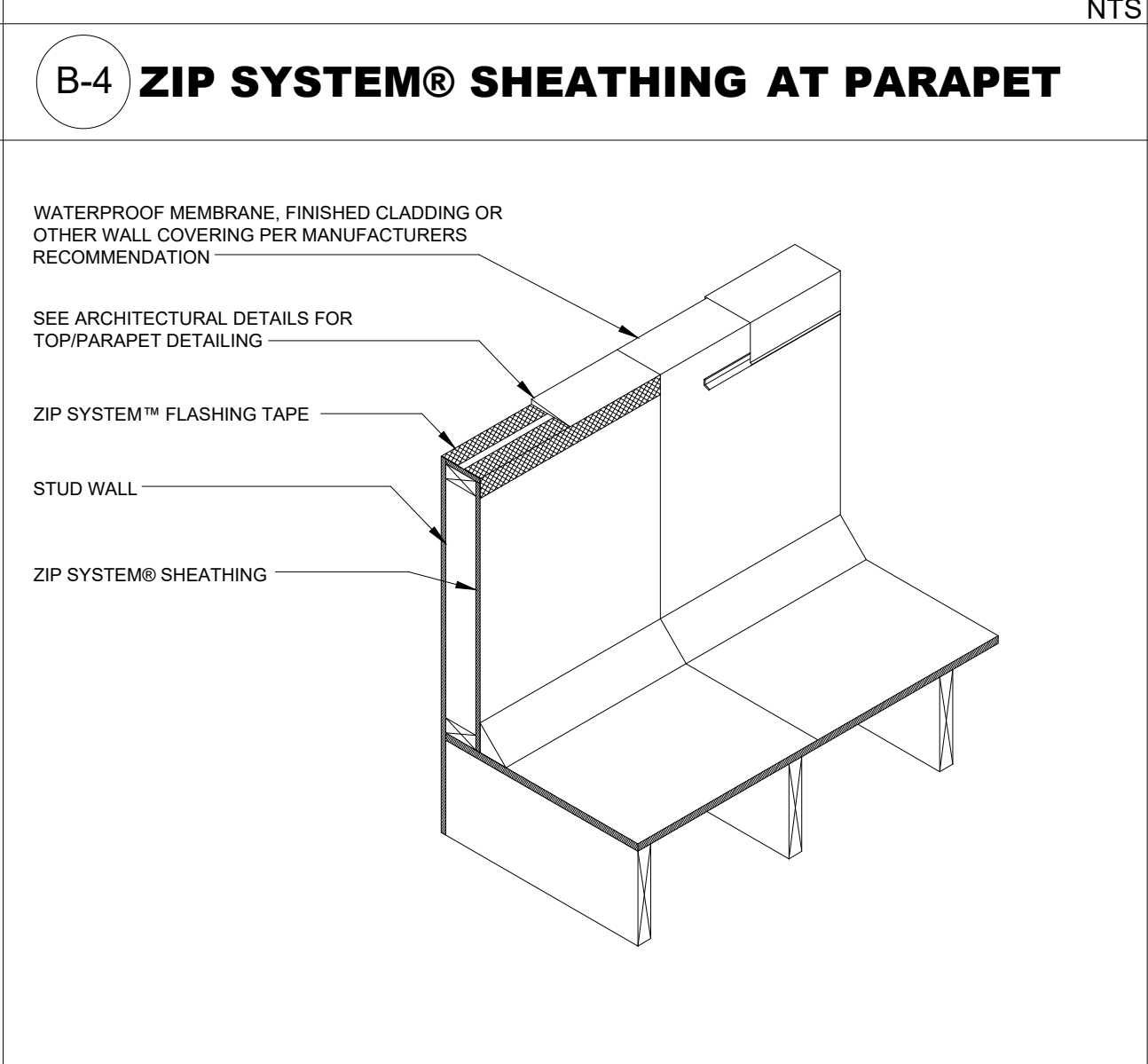
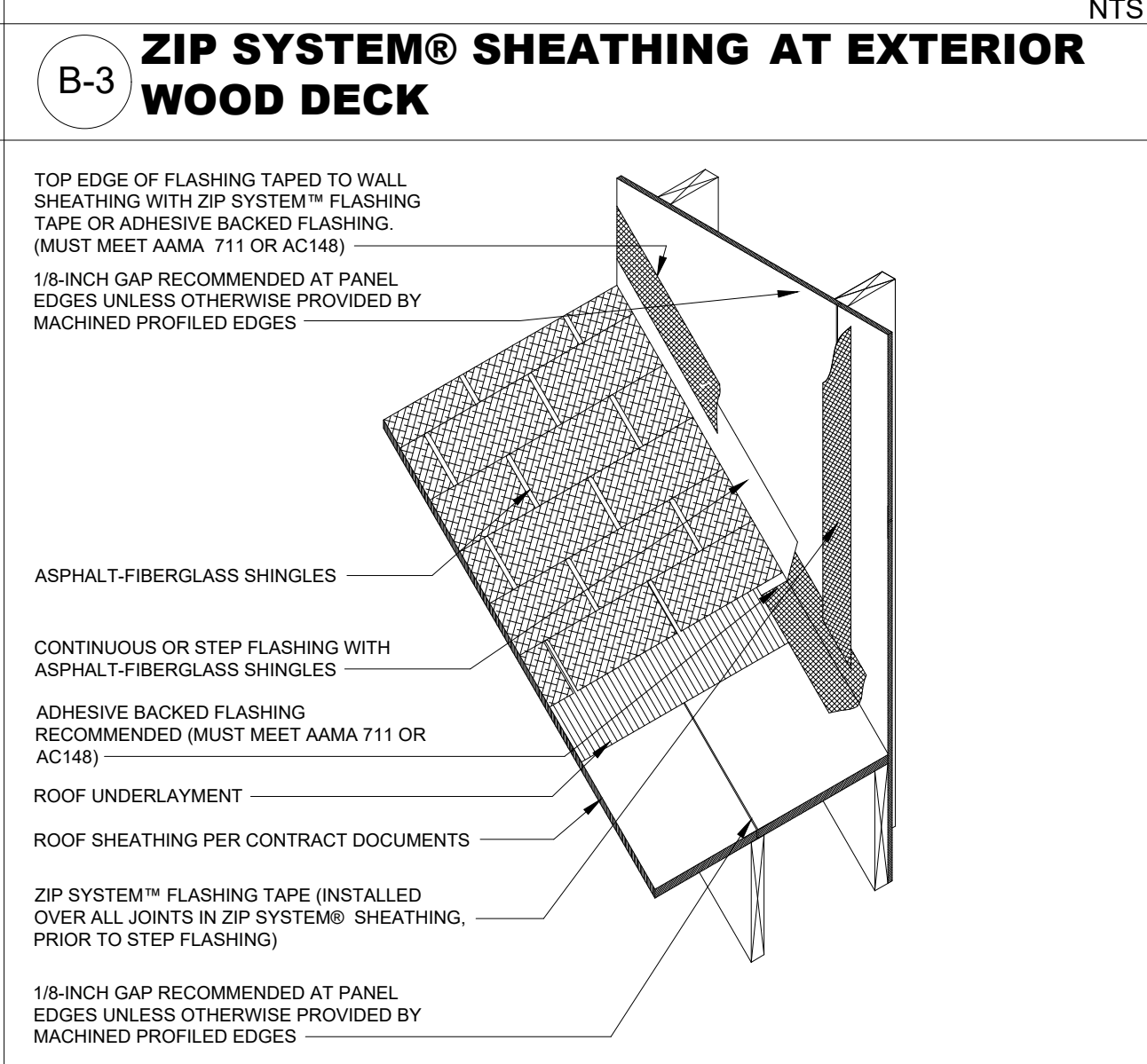
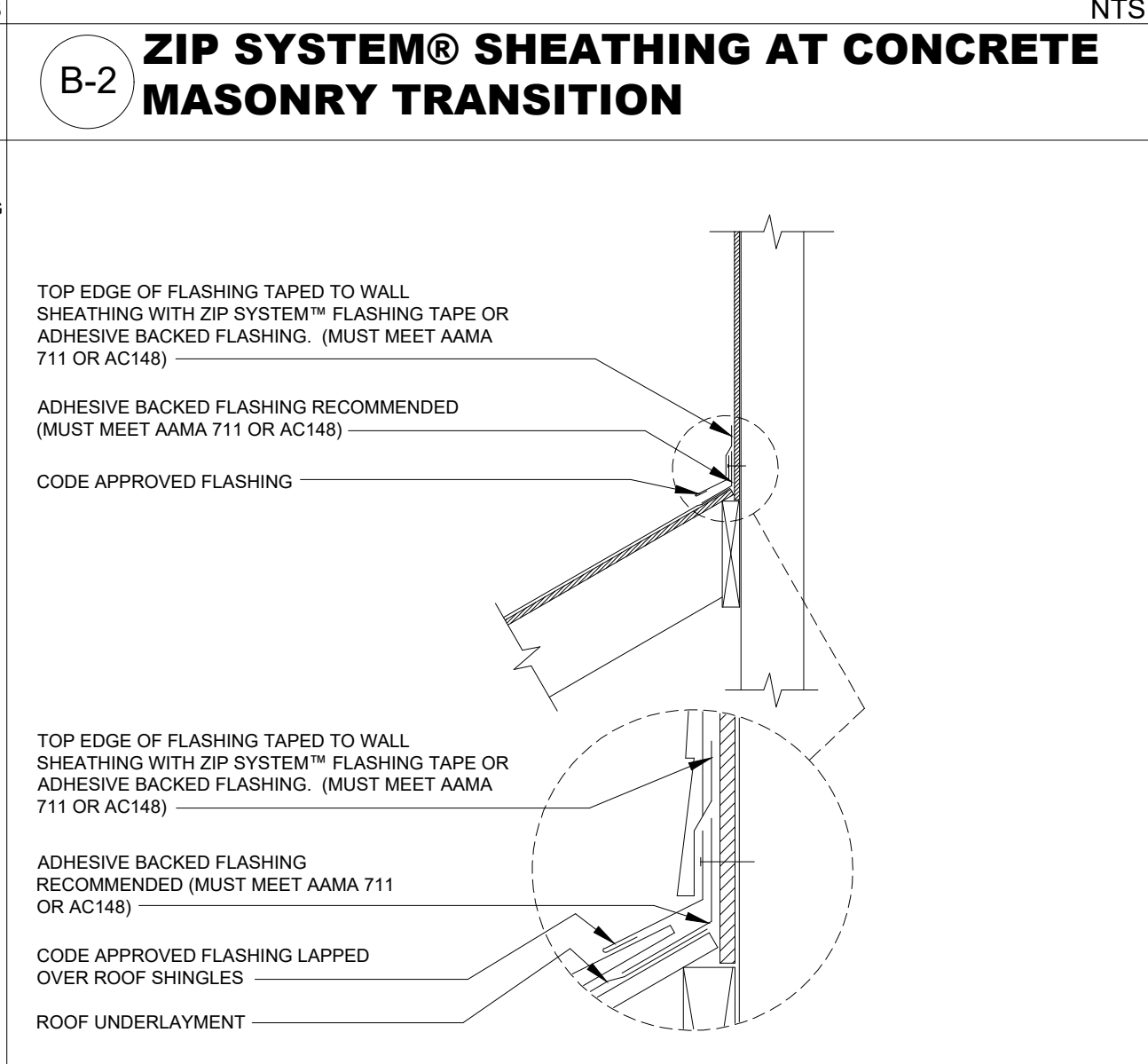
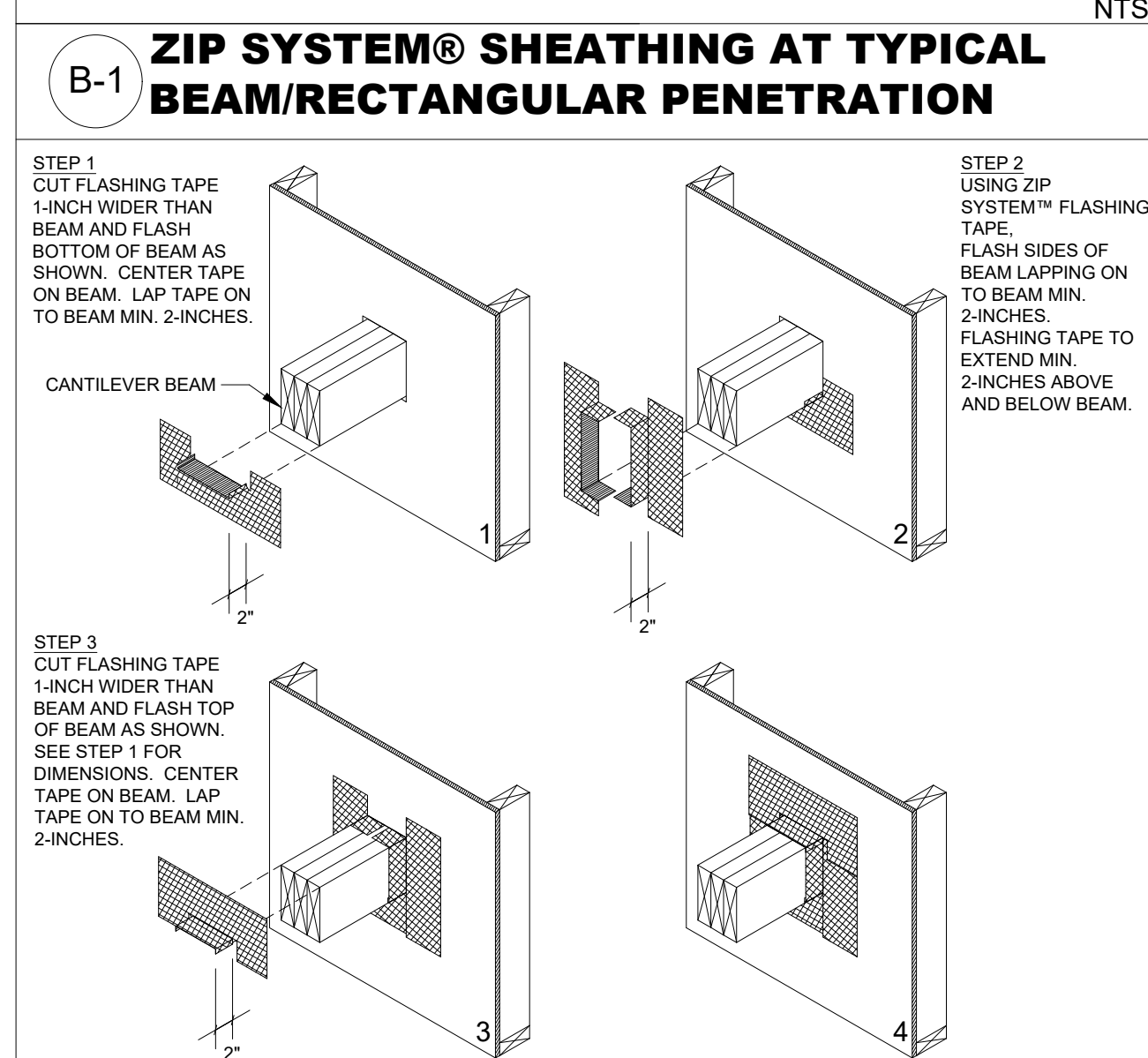

ZIP SYSTEM SHEATHING - WALL INSTALLATION INSTRUCTIONS

- INSTALL ZIP SYSTEM PANELS WITH THE WATER-RESISTIVE BARRIER FACING OUT. PANELS CAN BE ORIENTED VERTICALLY OR HORIZONTALLY. INSTALL BLOCKING WHEN USED AS A SHEAR WALL, PER THE STRUCTURAL PLANS, OR PER LOCAL CODE REQUIREMENTS. SPACE PANELS A MIN. 1/8".
- FASTEN THE PANELS TO THE FRAMING USING CODE-RECOGNIZED FASTENERS WITH MAXIMUM SPACING OF 6" O.C. ALONG SUPPORTED EDGES AND 12" O.C. AT INTERMEDIATE SUPPORTS. IT IS THE RESPONSIBILITY OF THE GENERAL CONTRACTOR TO VERIFY PROPER TYPE AND SPACING OF FASTENERS. A TIGHTER FASTENING MAY BE REQUIRED DEPENDING ON STRUCTURAL REQUIREMENTS. THE GC IS RESPONSIBLE FOR ENSURING OVER-DRIVEN FASTENERS AND SHINERS ARE ADDRESSED.
- TAPE ALL SEAMS USING ZIP SYSTEM FLASHING TAPE ENSURING THE TAPE IS CENTERED OVER THE SEAM WITHIN ± 1/2". USE A RUBBER-HEADED ROLLER TO APPLY ADEQUATE PRESSURE AND SMOOTH OUT ANY WRINKLES.
- VERTICAL OR HORIZONTAL TAPE SPLICES SHOULD OVERLAP A MIN. 3". AT T-JOINTS, THE TAPE PIECES SHOULD OVERLAP A MIN. 1".

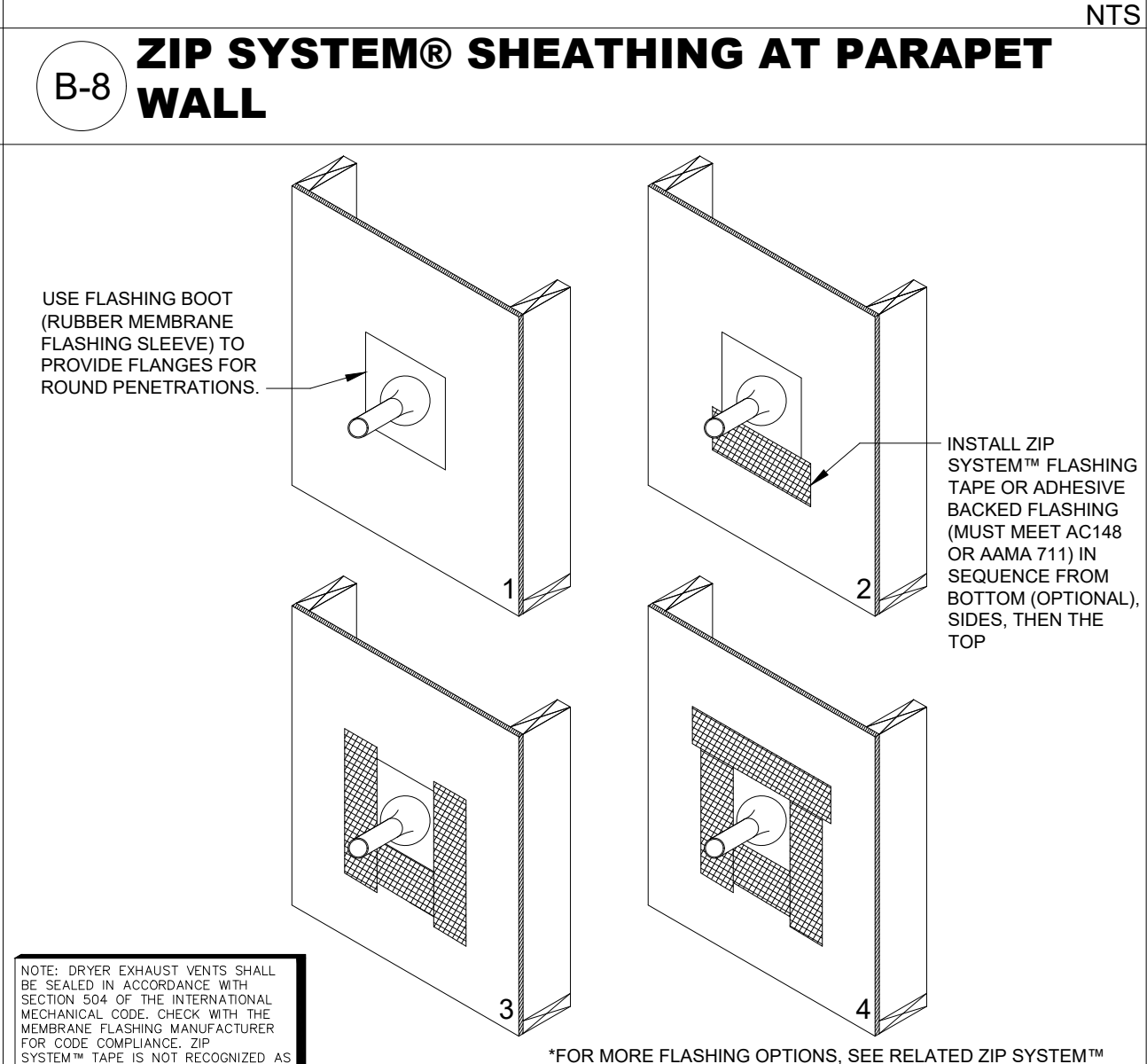
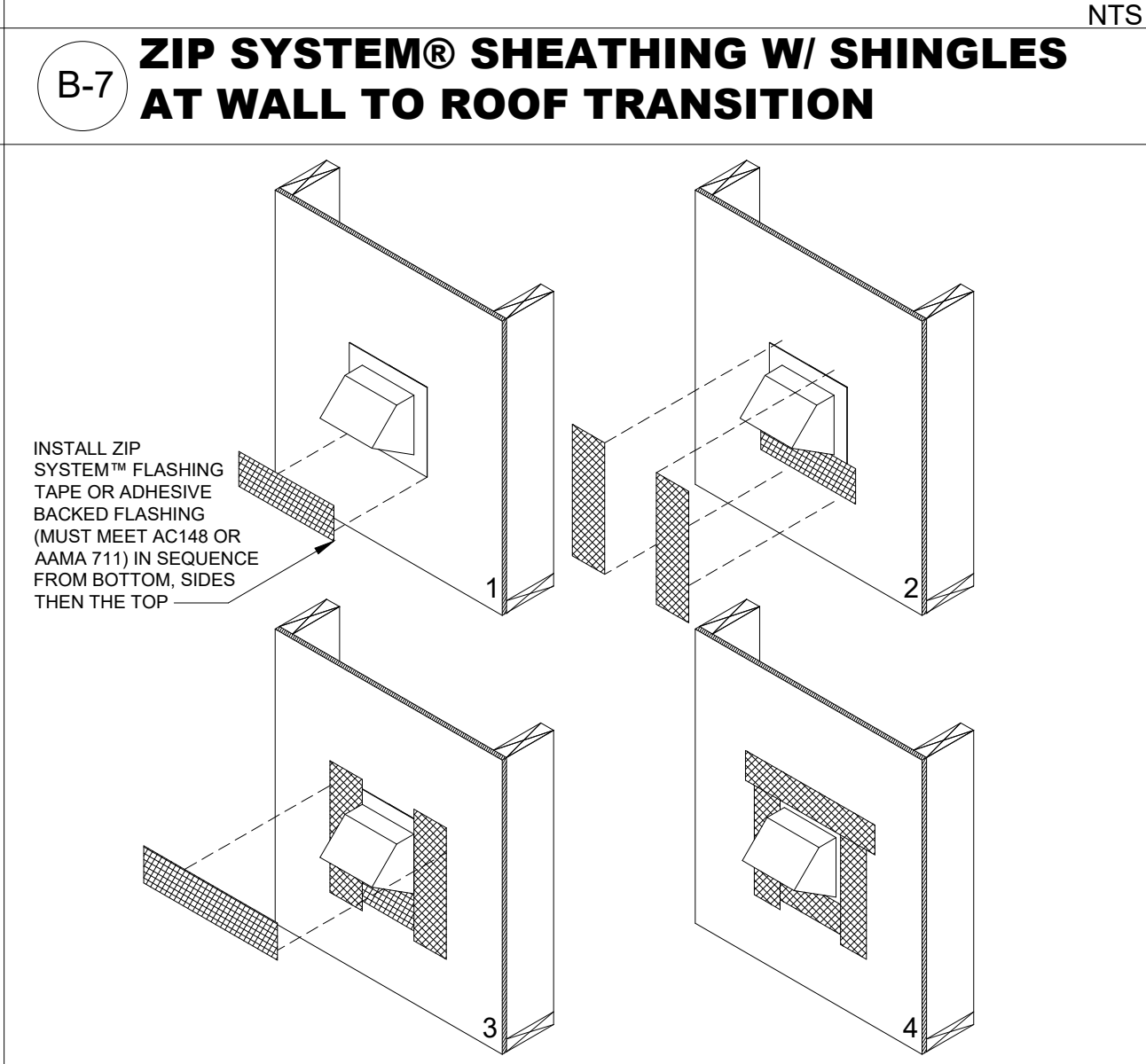
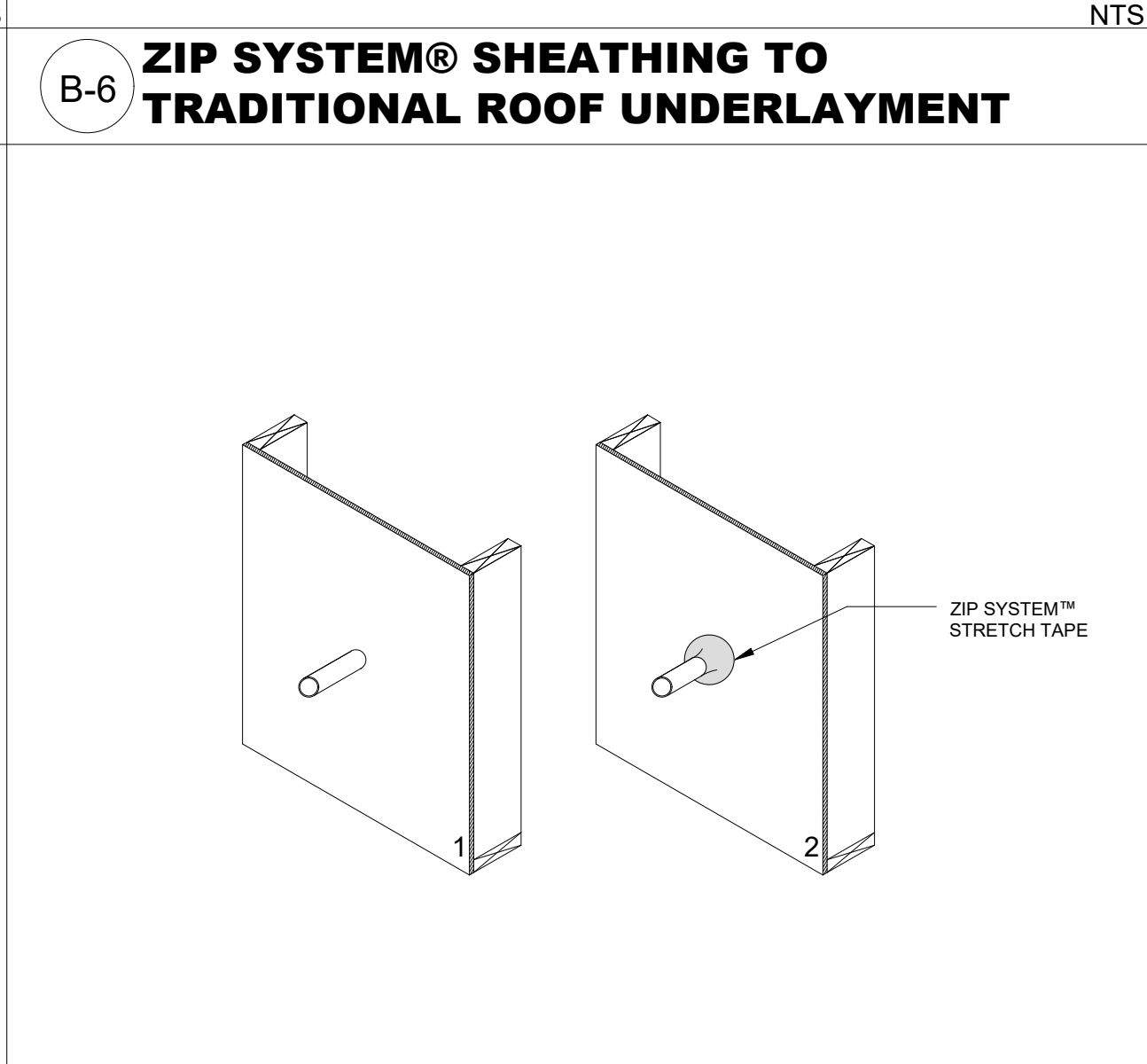
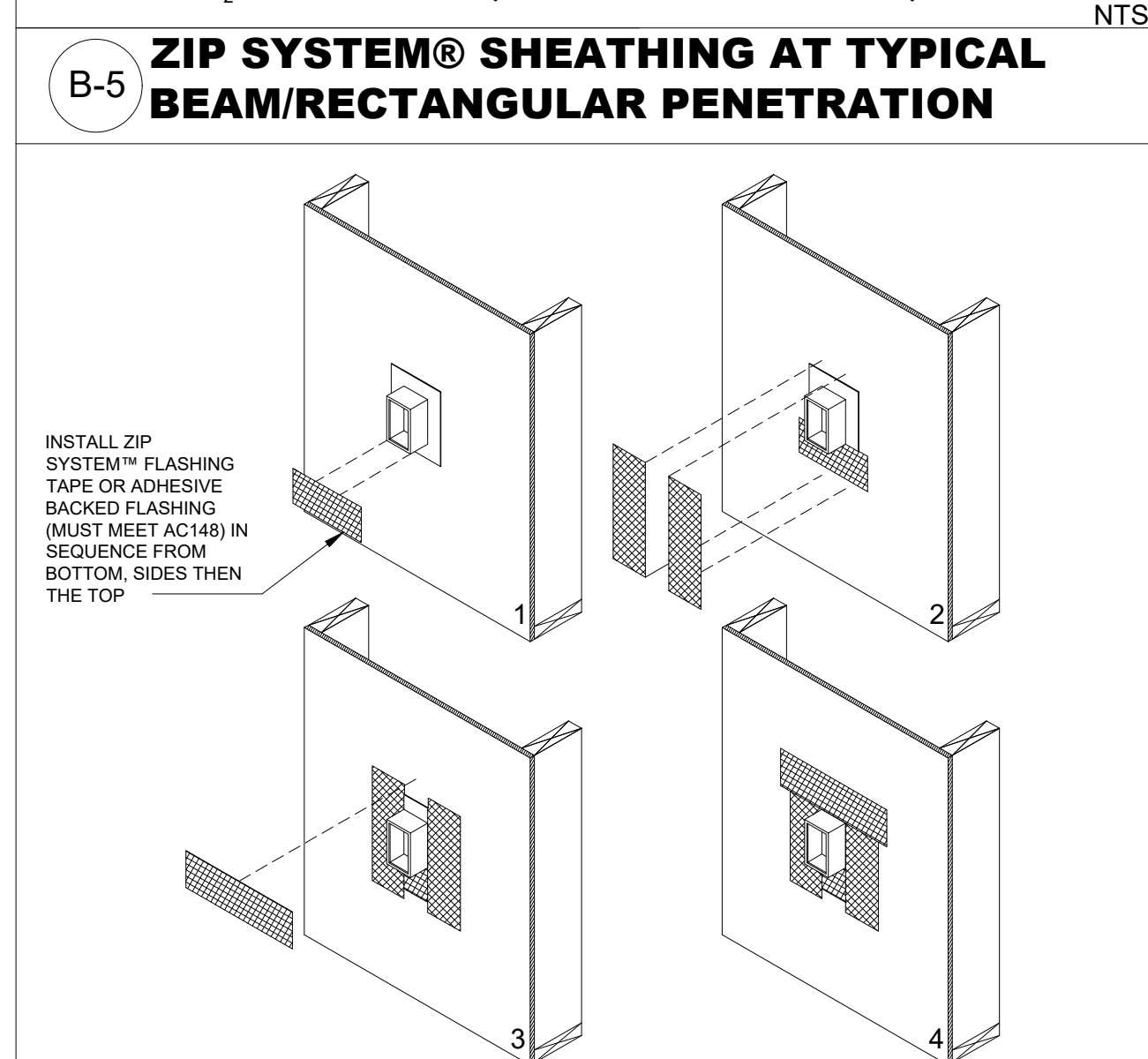

DISCLAIMER

THE DETAILS SHOWN ON THIS PAGE ARE TYPICAL AND FOR GENERAL PURPOSE. VISIT HUBERWOOD.COM FOR MORE INFORMATION ON FINISHED WALL COVERINGS, DETAILS, AND APPLICATIONS. SOME DETAILS ARE RECOMMENDATIONS BY HEW AND NOT REQUIREMENTS; SEE THE ZIP SYSTEM INSTALLATION MANUAL FOR MORE INFORMATION. A LIBRARY OF DETAILS AND TECHNICAL TIPS ARE AVAILABLE AT HUBERWOOD.COM.

FOR ADDITIONAL QUESTIONS CONTACT US BY EMAIL AT TECHQUESTIONS@HUBER.COM OR BY PHONE AT 1-800-933-9220 EXT. 2716

HUBER ENGINEERED WOODS, LLC
 10925 DAVID TAYLOR DRIVE
 SUITE 300
 CHARLOTTE, NC 28262

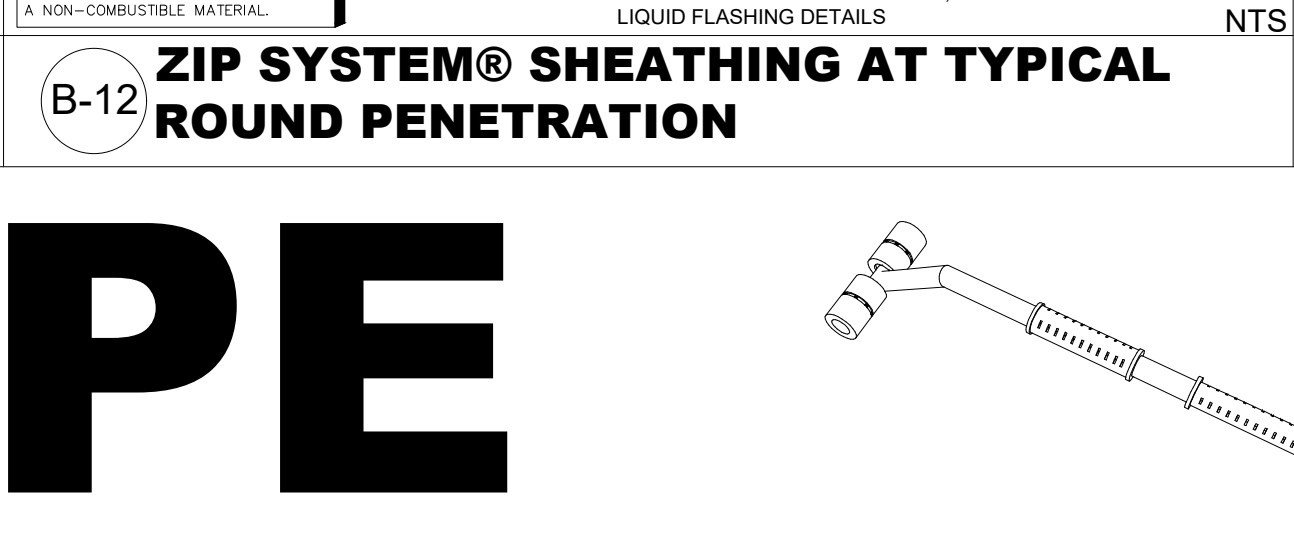
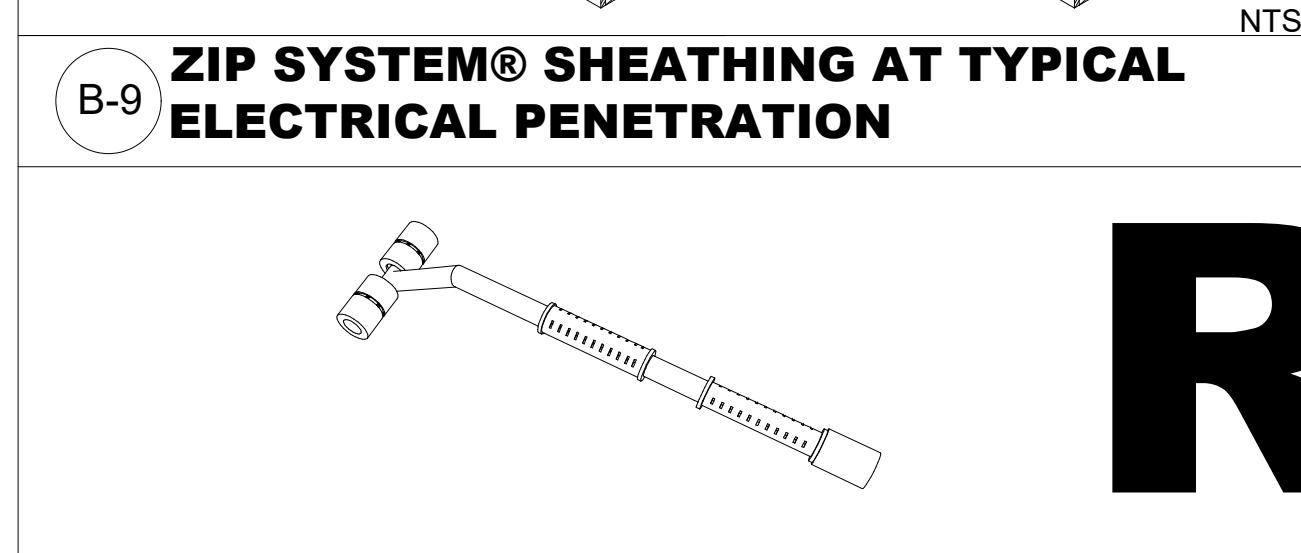

ROLL THE TAPE

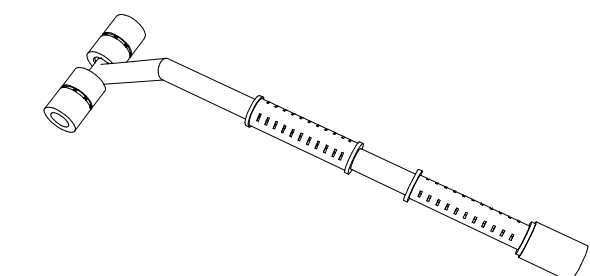
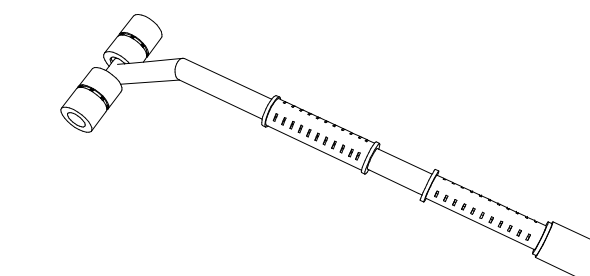

WINDOWS AND DOORS

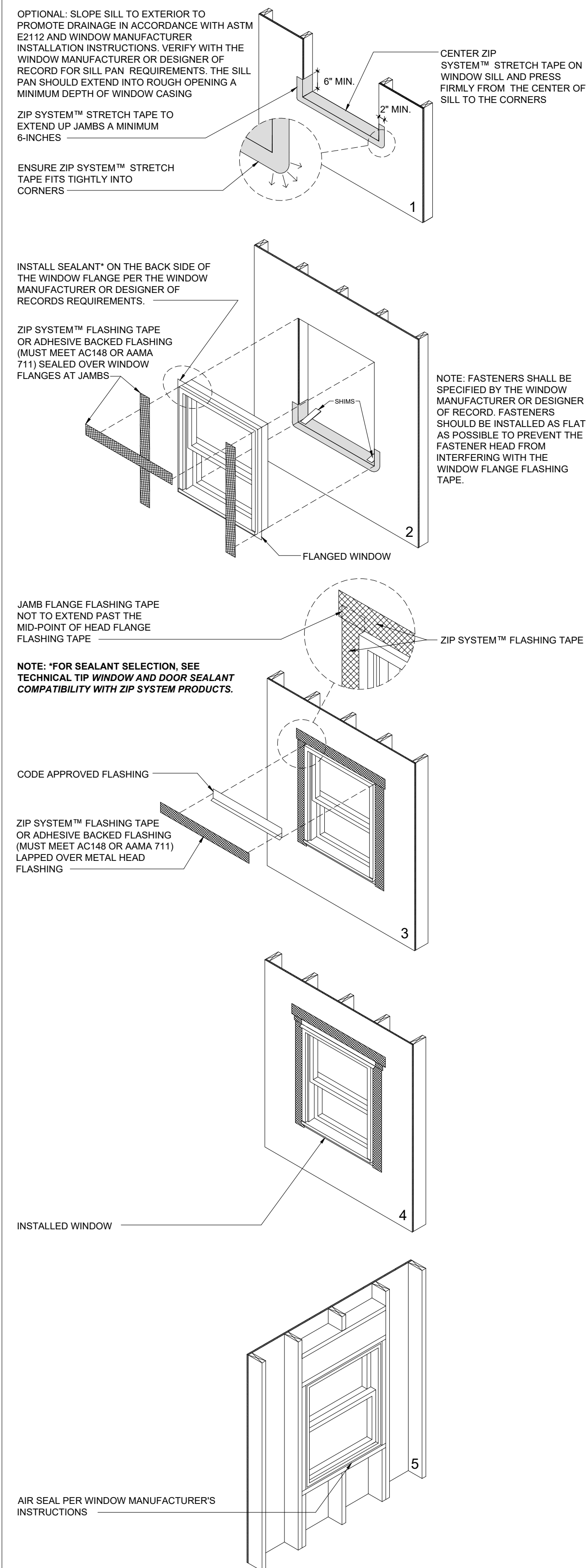

C-1 ZIP SYSTEM® SHEATHING WITH TYPICAL FLANGED WINDOW

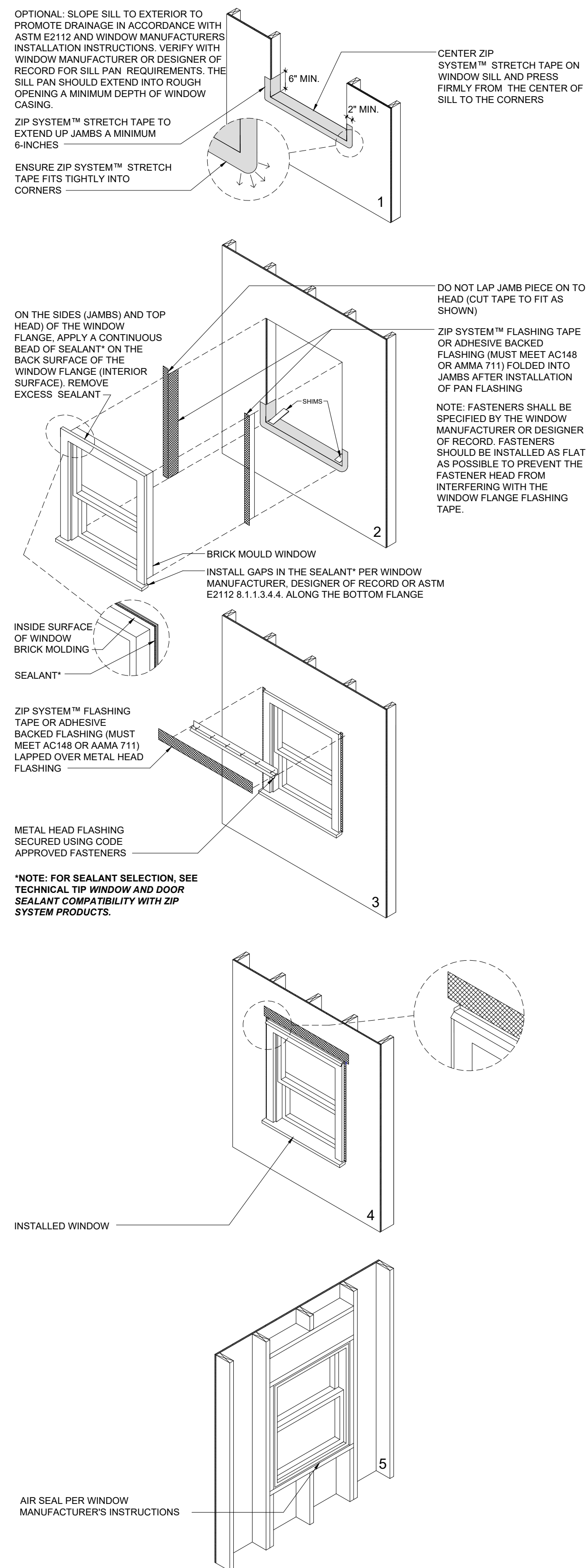

C-2 ZIP SYSTEM® SHEATHING WITH TYPICAL BRICK MOULD WINDOW

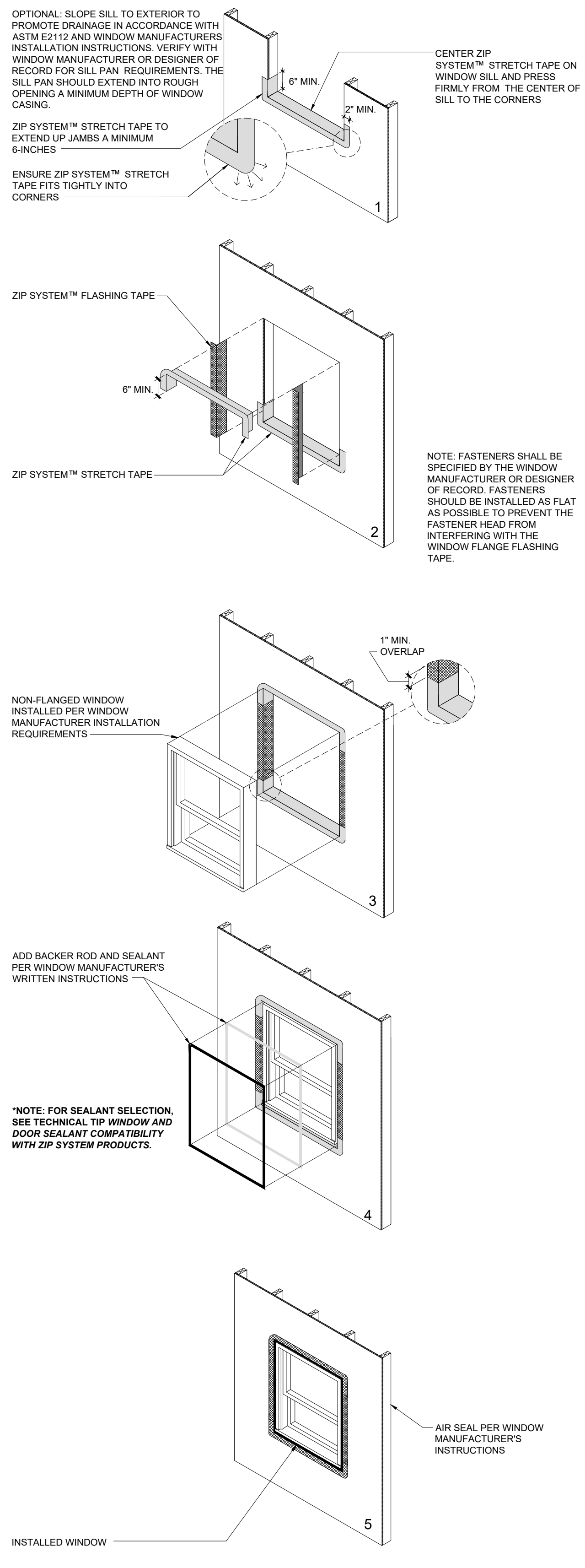

C-3 ZIP SYSTEM® SHEATHING AT TYPICAL STORE FRONT/FLANGELESS WINDOW

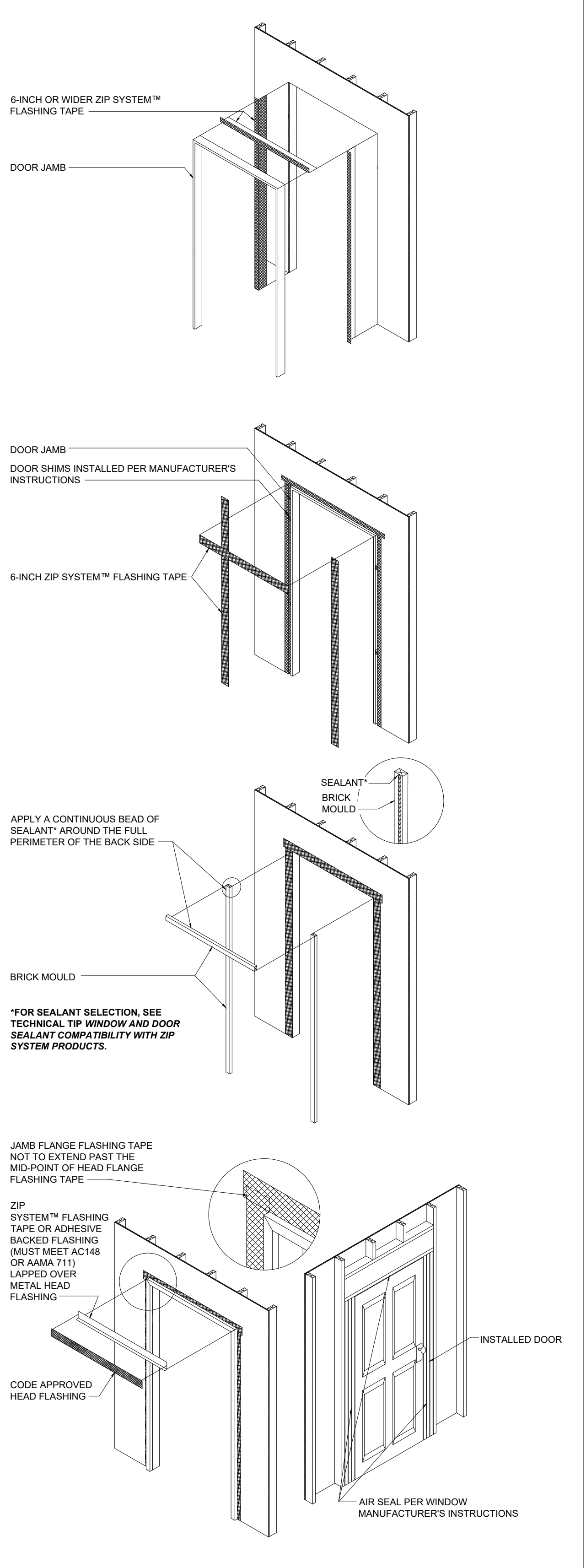

C-4 ZIP SYSTEM® SHEATHING AT TYPICAL DOOR INSTALLATION

ZIP SYSTEM® SHEATHING GENERAL NOTES

ZIP SYSTEM® SHEATHING IS A STRUCTURAL PANEL DESIGNED TO FUNCTION AS BOTH A STRUCTURAL SHEATHING PANEL AND A WATER-RESISTIVE BARRIER (WRB) TO STREAMLINE THE INSTALLATION PROCESS IN TYPE V CONSTRUCTION FOR WALL/ROOF APPLICATIONS AND IN TYPE III FOR ROOF APPLICATIONS. ZIP SYSTEM IS CODE-RECOGNIZED AS A WRB FOR A WALL APPLICATION PER ESR-1474 AND AS A ROOF UNDERLAYMENT PER ESR-1473. ALL ZIP SYSTEM PANEL SEAMS MUST BE TAPED USING THE ZIP SYSTEM™ FLASHING TAPE OR ZIP SYSTEM™ LIQUID FLASH. WHEN INSTALLING THE FLASHING TAPE, A RUBBER-HEADED ROLLER MUST BE USED. ZIP SYSTEM SHEATHING PANELS ARE DOC PS 2 STRUCTURAL 1 RATED COMPLIANT WOOD STRUCTURAL PANELS (WSP) HAVING AT LEAST THE SAME STRUCTURAL PERFORMANCE AS A WSP OF EQUIVALENT THICKNESS. FOR SHEAR WALL INFORMATION, SEE THE TECHNICAL TIP "SHEAR CAPACITY OF WOOD STRUCTURAL PANEL" AT HUBERWOOD.COM. ZIP SYSTEM PANELS ARE AVAILABLE IN THE FOLLOWING THICKNESSES.

- 24/16, STRUCTURAL 1, 7/16" PERF CATEGORY
 - 4'x8' | 4'x9' | 4'x10' | 4'x12'
 - | 4'x8' 1-1/8" | 4'x9' 1-1/8" | 4'x10' 1-1/8" | 4'x12' 1-1/8"
- 32/16, STRUCTURAL 1, 1/2" PERF CATEGORY
 - 4'x8' | 4'x9' | 4'x10'
- 40/20, STRUCTURAL 1, 5/8" PERF CATEGORY
 - 4'x8' | 4'x9' | 4'x10'

BELOW IS A SUMMARY OF THE ZIP SYSTEM SHEATHING INSTALLATION PROCESS, PLEASE VISIT HUBERWOOD.COM TO ACCESS THE COMPLETE ZIP SYSTEM INSTALLATION MANUAL

ZIP SYSTEM SHEATHING - WALL INSTALLATION INSTRUCTIONS

1. INSTALL ZIP SYSTEM PANELS WITH THE WATER-RESISTIVE BARRIER FACING OUT. PANELS CAN BE ORIENTED VERTICALLY OR HORIZONTALLY. INSTALL BLOCKING WHEN USED AS A SHEAR WALL, PER THE STRUCTURAL PLANS, OR PER LOCAL CODE REQUIREMENTS. SPACE PANELS A MIN. 1/8".
2. FASTEN THE PANELS TO THE FRAMING USING CODE-RECOGNIZED FASTENERS WITH MAXIMUM SPACING OF 6" O.C. ALONG SUPPORTED EDGES AND 12" O.C. AT INTERMEDIATE SUPPORTS. IT IS THE RESPONSIBILITY OF THE GENERAL CONTRACTOR TO VERIFY PROPER TYPE AND SPACING OF FASTENERS. A TIGHTER FASTENING MAY BE REQUIRED DEPENDING ON STRUCTURAL REQUIREMENTS. THE GC IS RESPONSIBLE FOR ENSURING OVER-DRIVEN FASTENERS AND SHINERS ARE ADDRESSED.
3. TAPE ALL SEAMS USING ZIP SYSTEM FLASHING TAPE ENSURING THE TAPE IS CENTERED OVER THE SEAM WITHIN ± 1/2". USE A RUBBER-HEADED ROLLER TO APPLY ADEQUATE PRESSURE AND SMOOTH OUT ANY WRINKLES.
4. VERTICAL OR HORIZONTAL TAPE SPLICES SHOULD OVERLAP A MIN. 3". AT T-JOINTS, THE TAPE PIECES SHOULD OVERLAP A MIN. 1".

DISCLAIMER

THE DETAILS SHOWN ON THIS PAGE ARE TYPICAL AND FOR GENERAL PURPOSE. VISIT HUBERWOOD.COM FOR MORE INFORMATION ON FINISHED WALL COVERINGS, DETAILS, AND APPLICATIONS. SOME DETAILS ARE RECOMMENDATIONS BY HEW AND NOT REQUIREMENTS; SEE THE ZIP SYSTEM INSTALLATION MANUAL FOR MORE INFORMATION. A LIBRARY OF DETAILS AND TECHNICAL TIPS ARE AVAILABLE AT HUBERWOOD.COM.

FOR ADDITIONAL QUESTIONS CONTACT US BY EMAIL AT TECHQUESTIONS@HUBER.COM OR BY PHONE AT 1-800-933-9220 EXT. 2716

HUBER ENGINEERED WOODS, LLC
10925 DAVID TAYLOR DRIVE
SUITE 300
CHARLOTTE, NC 28262

ROLL THE TAPE

